

CONTRACTOR AMPLIFIERS

EX

Application Guide

QSCTM
AUDIO

Table of Contents

Distributed line principles	3
Sidebar: <i>Ohm's Law</i>	4
Why 70 volts?	4
Sidebar: <i>Transforming voltages and impedances</i>	5
"Natural" voltages	5
Designing the distributed sound system.....	6
Loudspeaker coverage and placement	6
Sidebar: <i>Reverberation and RT_{60}</i>	7
Sidebar: <i>The Inverse Square Law</i>	8
Determining power levels	9
Calculating total power requirements	11
Fitting amplifier power	12
Using components with different line voltages	13
Sample applications & output configurations	14
Other design considerations	16
Speaker transformer saturation	16
Sidebar: <i>Installation tip</i>	16
Speaker wire loss	17
AC current consumption	19
Thermal losses (heat emissions)	20
System design with CX Series amplifiers	21
Features	22
The inner workings	22
Exclusive CX features and accessories	23
DataPort	23
Accessories	23
IT-42 isolation transformer pack	24
Crossover and filter modules	24
Front & rear panels	25
Specifications	28
Address & Telephone Information	30

©Copyright 1996, 1999 QSC Audio Products, Inc. All rights reserved.
QSCControl is a trademark of QSC Audio Products, Inc.
"QSC" and the QSC logo are registered with the U.S. Patent and Trademark Office.

CX Series Application Guide

With the helpful advice and input from contractors and consultants around the world, engineers at QSC designed the CX Series amplifiers to be a versatile and reliable foundation for high quality installed sound systems.

This applications guide will help you design your sound system properly and utilize your CX amplifier(s) effectively. It starts with a tutorial on distributed (constant voltage) speaker systems.

Distributed line principles

The best way to power a system of numerous relatively low-powered loudspeakers from a single amplifier is to use a distributed line, which combines the simplicity of connecting speakers in parallel across a pair of wires with the versatile capability to individually tailor the power delivered each speaker.

Distributed lines, often called constant-voltage lines, are categorized by their maximum RMS voltage: 25-, 70-, 100-, 140-, 200-volt, etc. The name “constant voltage” can be misleading because it suggests that the voltage on the line does not correlate to the audio signal level. But in fact, there’s nothing constant about the voltage on a “constant-voltage” line; the voltage on the distributed line is indeed an audio signal and will modulate as the audio itself does. If you connect a voltmeter across a 70-volt line, you will seldom actually measure 70 volts except on audio peaks. If the audio is muted, you will measure zero volts.

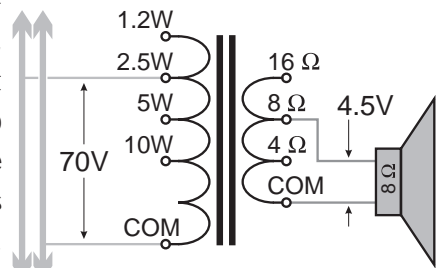

Example of a loudspeaker connected to a distributed line through a transformer

Distributed-line amplifiers are designed to produce maximum power at the line voltage. For example, a 70-volt amplifier will produce its maximum power at 70 volts, regardless of whether it’s a 50-watt, 150-watt, or 700-watt model.

What will differ from one power rating to another is the amount of current the amp can put out, as you can determine by using Ohm’s Law. (If you need to brush up on Ohm’s Law, see the sidebar on the next page.) Thus, a 70-watt amp is designed to put out as much as 1 ampere at 70 volts, while a 350-watt amp will be able to produce up to 5 amperes at that voltage. Compare that to regular low-impedance amplifiers, whose power ratings are directly related to the maximum voltages the amps can put into 8, 4, or 2 ohms, so that a higher-powered amp has a higher output voltage for a given load than a lower-powered amp does. For instance, an amplifier rated at 100 watts into 8 ohms can put out

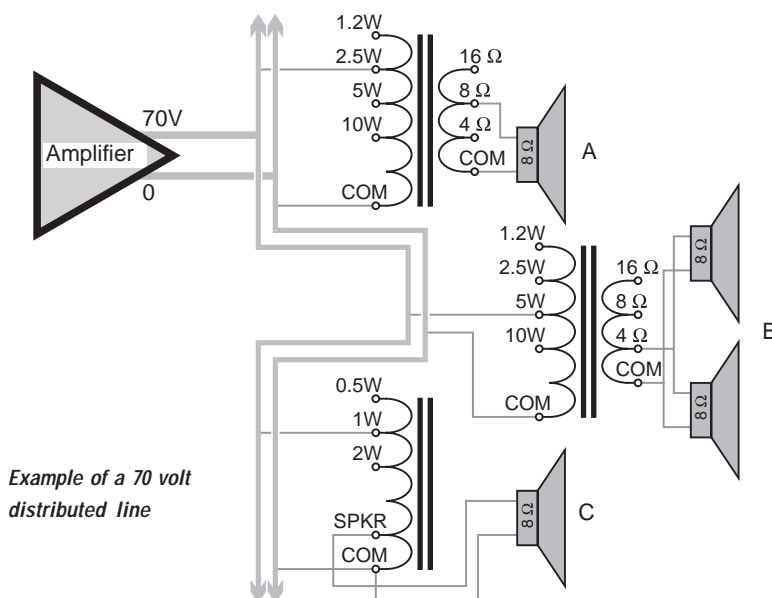

Example of a 70 volt distributed line

as much as 28.3 volts, as determined by Ohm's Law, while an amp that does 200 watts into 8 ohms can put out 40.0 volts.

This is where the true concept of "constant voltage" comes in; it helps simplify system design by converting one of the variables into a constant value. But you can't just connect typical 8-ohm speakers across a 70-volt line because they'll want to draw about 625 watts each. How then do you plan and control the amount of power to each speaker when you have a defined maximum line voltage? The answer: through transformers. Each speaker has a transformer that converts the line voltage to another value (almost always lower) to actually drive the speaker. Taps on the transformer allow you to select the power level the speaker receives when the line voltage reaches its maximum of 70 volts. It is somewhat analogous to AC electrical service, in that you can plug a 100-watt appliance and a 50-watt one into outlets carrying the same 120 VAC; you don't have 120 volts for one and 85 volts for the other.

Regular low-impedance amplifiers are perfect for systems with one, two, three, or four speakers per amp channel, with each speaker getting the same amount of power. But if you need to power more speakers, or provide different power levels to some or all of them, you would often have to do some complicated series-parallel calculations and wiring. And even then if a speaker fails, is removed, or must be added, it would alter the power distribution among the rest. A distributed line eliminates the need for such calculations and considerations. It lets you forget about impedances. And it also lets you substitute amplifier models as needed without having to re-calculate power distribution among the loudspeakers. For example, if expanding a distributed speaker system or increasing some power taps requires you to upgrade a 150-watt 70-volt amplifier to a 200-watt model, you can do so without re-calculating or reconfiguring all the other speaker taps, although you would have to match the gain of the new amp to that of the old one.

Why 70 volts?

If 70 volts seems like an odd number to become a de facto standard for distributed line voltage, how about 70.7 volts? That's the actual figure used in design of distributed lines, although it suggests a lot more precision than you should hope to measure on an audio voltage. The number 70.7 came about for two reasons. First, as we've seen already in this book, many loading and impedance calculations involve squaring the voltage. The approximate square of 70.7 is 5000, which was easy to remember and work with in the days before pocket calculators. The second reason is that versions of the National Electrical Code (NEC) before 1999 classify signal circuitry of 100 volts or higher as Class 1, requiring a higher grade of wiring. Settling on 70.7 volts allowed a distributed line circuit to be deemed a Class 2 circuit, with a safety margin of exactly 3 dB to allow for loading variations, audio peaks, etc.

Distributed line voltages other than 70 volts are common in some areas and applications. In Europe, 100-volt lines are prevalent instead of 70 volts. And in the United States, 25-volt lines are common in public school buildings. In applications where distributed lines have to run very long distances, 140- and 200-volt lines carry the audio power at a high ratio of voltage to current (a high-impedance line, in other words) to minimize losses due to wire resistance.

Ohm's Law

Nearly two centuries ago a German scientist named Georg Ohm discovered that the current through a load is directly proportional to the voltage across it, and also inversely proportional to the resistance of the load. This relationship is called Ohm's Law, and the scientific community honored Ohm by naming the unit of resistance after him. In its basic form, Ohm's Law is expressed as the equation

$$E = I \times R$$

where E is voltage (in volts), I is current (in amperes), and R is resistance (in ohms).

You can also use Ohm's Law to calculate the power in the load, which is equal to voltage times current. The properties of power, voltage, current, and resistance are all interrelated, so if you know the value of

any two of them, you can calculate the other two. This Ohm's Law "wheel" shows how to solve for any of the four properties.

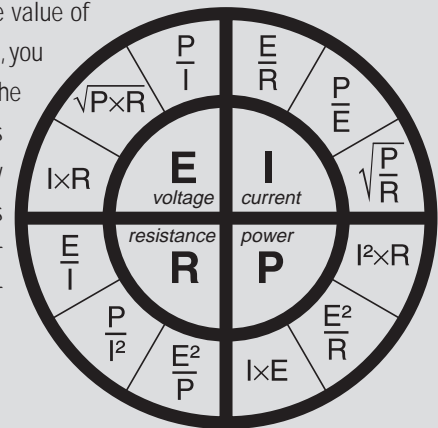

Transforming voltages and impedances

Imagine driving a system of 100 8-ohm speakers at a low power (say, 8 watts each) with a single amplifier, like you might need to do in an office building's paging system. How would you do it? Connect them all in parallel, perhaps with 00 AWG cable to wire them all together, and find a power amp that can do 800 watts into 0.08 ohms, which comes out to 8 volts and 100 amperes?

That's not practical, not the least because no such amplifier exists!

Or would you use a 70-volt amp with a rating of 800 watts or better, and put a transformer on each speaker to provide the desired power level? Then the amp has to put out 70 volts at 11.4 amperes, for an equivalent load of 6.13 ohms. That's much more reasonable.

A speaker transformer steps the line voltage down to a lower level to drive the speaker. In doing so, it also steps up the speaker impedance, so that the line itself

sees the speaker/transformer combination as a relatively high impedance.

For example, the transformers in this example have an 8.75:1 voltage step-down, converting 70 volts from the distributed line to 8 volts for the speaker. Into an 8-ohm speaker, that will produce 8 watts.

The ratio of the impedance step-up is equal to the square of the voltage ratio in the other direction. Therefore, the 8-ohm impedance of the speaker driver will be multiplied by a factor of 76.56, resulting in the line seeing a theoretical impedance of 613 ohms. (The actual figure will be somewhat less because of the transformer's insertion loss.)

The importance of this phenomenon is that the high impedances allow you to connect many speakers—25, 50, 100, etc.—in parallel on the line, which you would not be able to do with speakers alone in a practical way.

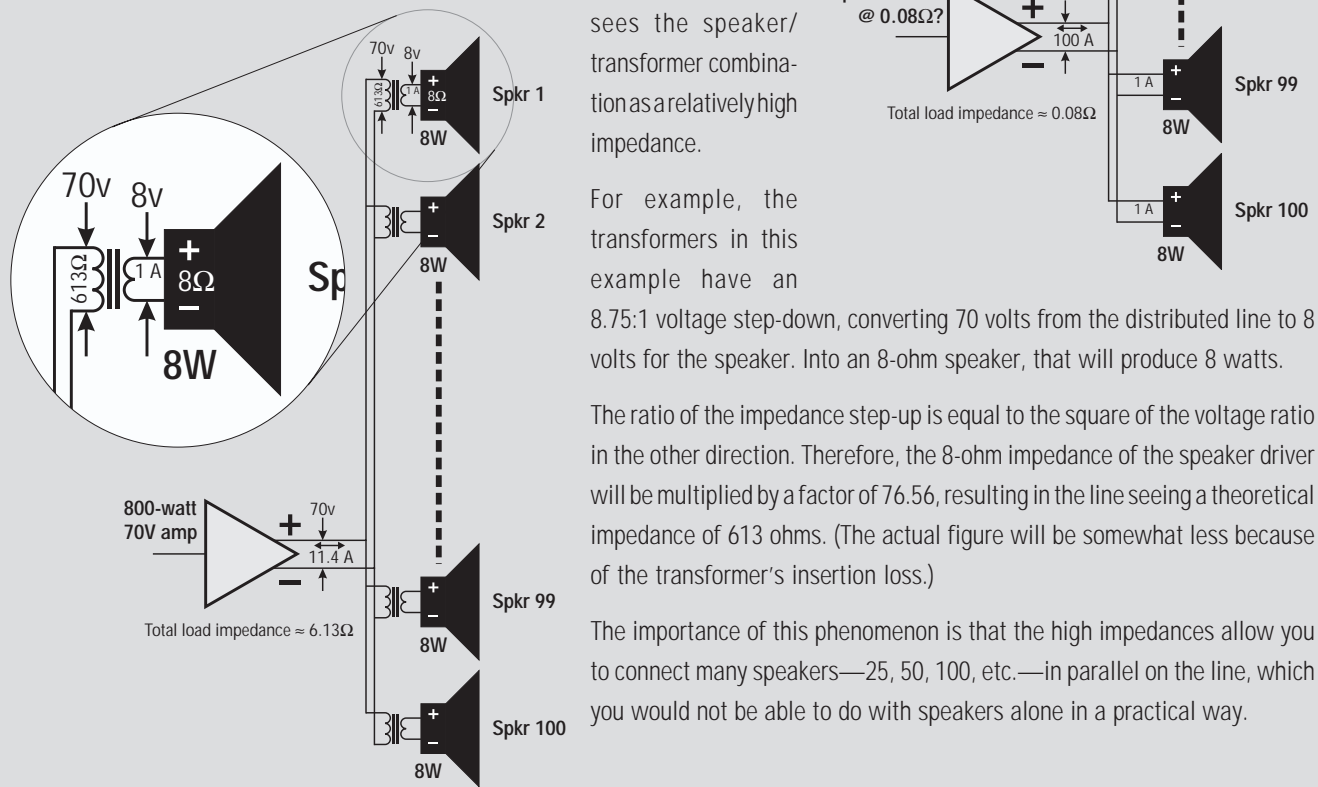

"Natural" voltages

Some power amps designed for powering direct low-impedance speaker loads have power ratings that make them suitable for driving distributed lines, too. An 8-ohm load draws 625 watts at 70.7 volts, so an amp rated for 600 to 650 watts into 8 ohms is often termed a "natural" for driving a 70-volt line. This relationship works for other line voltages, too, although they are rare for 100 volts and higher:

25V	75–80 watts @ 8Ω	150–160 watts @ 4Ω	300–320 watts @ 2Ω
70V	600–650 watts @ 8Ω	1200–1300 watts @ 4Ω	2400–2600 watts @ 2Ω
100V	1200–1300 watts @ 8Ω	2400–2600 watts @ 4Ω	4800–5200 watts @ 2Ω
140V	2400–2600 watts @ 8Ω	4800–5200 watts @ 4Ω	
200V	4800–5200 watts @ 8Ω	9600–10400 watts @ 4Ω	

Designing the distributed sound system

There are several main steps in designing a distributed sound system:

- Determining loudspeaker coverage and placement
- Determining power levels for each loudspeaker
- Choosing the right amplifier

Loudspeaker coverage and placement

In placing loudspeakers in a distributed system, the goal is to provide coverage effectively but economically. An effective coverage would be one where the sound from the loudspeakers is not only audible, but also intelligible, wherever needed. An economical coverage would tend to be one that achieves the goal using the fewest loudspeakers necessary.

A loudspeaker in an enclosed area produces two sound fields. The main one is the direct field—sound coming directly “line-of-sight” from the loudspeaker. Primary and secondary reflections can also be considered part of the direct sound field, as long as their delays are short enough to psychoacoustically reinforce the original sound. The other is the diffuse field (sometimes called the reverberant field), which is sound that you might call “post direct.” This diffuse field of reverberation is sound that has bounced around the room, reflecting off surfaces such as floors, walls, tables, ceilings, etc., until it is absorbed by the air, other objects, and the room itself. The diffuse field is comprised of multiple sound wave fronts traveling in different directions, each taking a slightly different length of time to arrive at the listener (or microphone). As a result, a common characteristic of the diffuse field is “image smearing,” which reduces the intelligibility of the sound.

Thus, to keep intelligibility high, you should maximize the ratio of direct field to diffuse field. As the Inverse Square Law dictates (see the sidebar on page 8), the direct field sound falls off as the distance from the loudspeaker increases. The diffuse field is also subject to the Inverse Square Law, but moving away from one reflective surface often moves you towards another; as a result, the intensity of the diffuse field usually doesn't vary significantly throughout a room. The graph at right shows the direct, diffuse and combined sound fields (direct and diffuse, summed) of a single loudspeaker in a large, fairly reverberant room. Closer to the speaker, the direct field is much stronger than the diffuse field; intelligibility here will be very good to excellent, but it will drop off as you move further away. At the critical distance, D_c , the direct and diffuse fields are equal in intensity, and beyond D_c the diffuse field overpowers the direct. At this position a person speaking clearly though the sound system might be heard, but not clearly enough

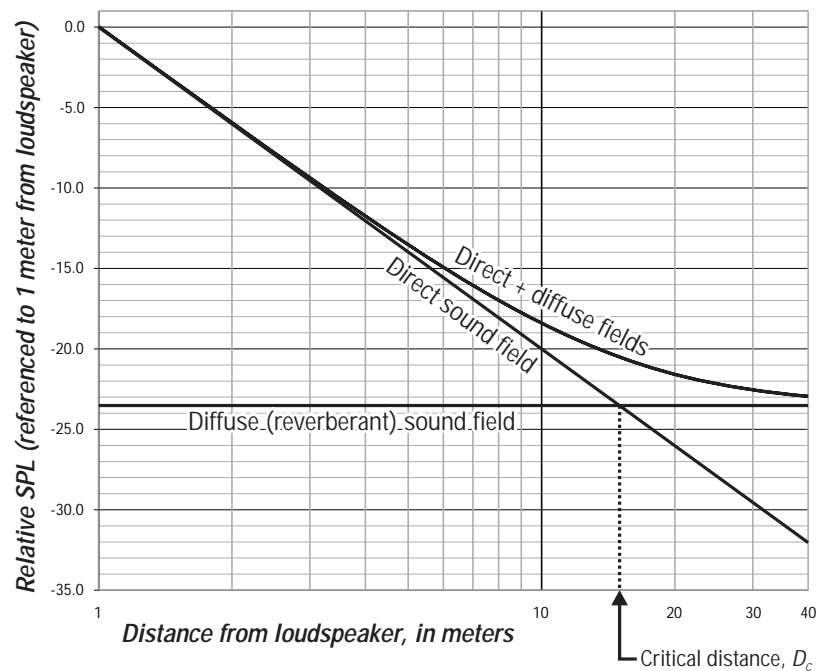

Intensity of direct and diffuse sound fields in an enclosed space

Reverberation and RT_{60}

A common and useful measurement of a room's reverberance is its reverberation time, or RT_{60} . It is defined as the time it takes a sound in a space to decay 60 dB (or one millionth of the acoustic power). The more reverberant the room, the longer the RT_{60} . Reverberation time is most precisely measured with special test gear such as MLSSA or TEF equipment or the SMAART system.

In general, shorter values tend to be better for speech, while longer ones tend to make music, particularly instrumental, sound fuller and more pleasing to the ear.

Here are typical targeted reverberation times for various types of venue:

Conference halls, meeting rooms, etc.	0.6–1.2 seconds
Cinemas	0.8–1.2 seconds
Live theater (including musical and variety shows)	1.0–1.4 seconds
School halls, multi-use rooms	1.0–1.5 seconds
Opera houses	1.0–1.6 seconds
Recital and chamber music halls	1.2–1.6 seconds
Concert halls (orchestral)	1.6–2.2 seconds
Organ and choral music	2.0–4.0 seconds

to be understood: this is the “what did he/she say?” syndrome. In this example, D_c is approximately 15 meters.

Not all reverberation is detrimental. A controlled amount, either natural or added electronically, can enhance the aesthetics of speech and, to a greater extent, music. However, adding electronic reverb on a sound system designed for mostly utilitarian purposes—e.g., paging or recorded background music—is very rare.

The less reverberant the room, the less intense the diffuse sound field will be, and D_c will be greater. Conversely, increased reverberance of a room will shorten D_c and sharply reduce the intelligible coverage area of the sound system. Increasing the power to the loudspeaker is not a remedy, because the increased direct field in turn excites the diffuse field. The result is the relationship between direct and diffuse fields will stay about the same. And to make matters worse, the likelihood of feedback through an open microphone increases.

Solutions to maximizing sound system intelligibility in a difficult room include:

- controlling the reverberant nature of the room through acoustical treatment of reflective surfaces, and architectural means.
- controlling coverage by using loudspeakers with directional qualities (Q) that will help keep sound on the audience and off the walls and other surfaces.
- using many low-powered loudspeakers close to the audience instead of one (or a few) centrally located high-powered loudspeakers. This often also requires less total audio power and the production of less acoustic energy, which further helps reduce the diffuse field.

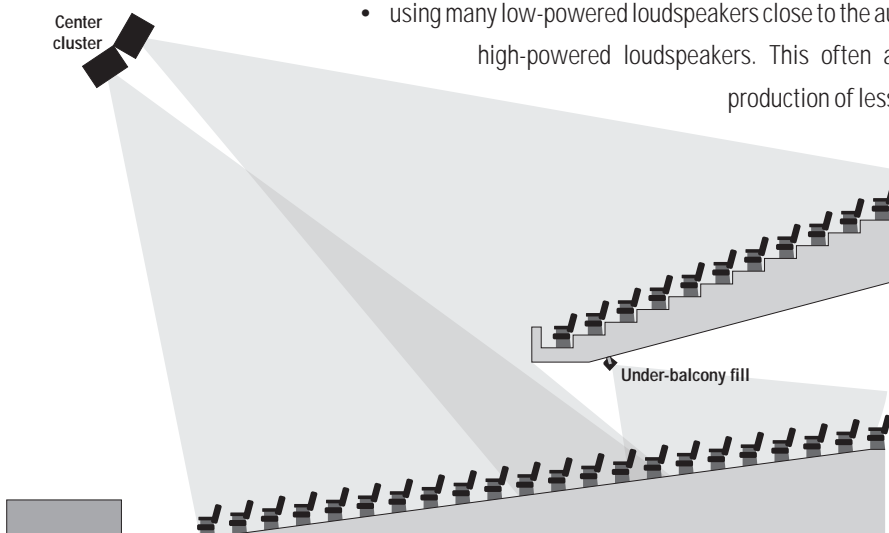

The last approach is often best accomplished through a distributed line speaker system. A distributed line might also be useful for covering problematic areas in a room, such as the under-balcony seating in a theater served by a center cluster; a line of small speakers under the balcony, as illustrated at left, could help provide good sound to that portion of the audience.

One of the most common uses of distributed lines is to power ceiling speakers in office, retail, and commercial buildings. With ceiling-mounted loudspeakers, one common rule of thumb is to make the center-to-center distance between them no greater than twice the floor-to-ceiling distance. Used with loudspeakers that have a 90° angle of coverage, this is often suitable for background music systems, but for paging and public address applications it tends to have somewhat erratic coverage at normal sitting and standing positions, as the illustration below shows.

The Inverse Square Law

The Inverse Square Law says that as a sound wave travels away from its source, its intensity, or sound pressure level, is inversely proportional to the square of D , the distance from its source.

Therefore, the intensity of a sound wave when $D=2$ meters is only 1/4 of what it was at 1 meter; at 3 meters, it'll be 1/9, and at 4 meters, 1/16. In decibels, 1/4 power is equal to -6 dB; that's why the Inverse Square Law is often stated as "-6 dB every time you double the distance."

Sound waves travel outward from a source, such as a loudspeaker or a person's mouth, in all directions. The sound might be stronger in some directions than others, but it all travels at the same velocity. Therefore, sound waves tend to be spherical, or partially spherical, around the source. The area of a sphere is proportional to the square of its radius (analogous to D); the energy of the sound wave is distributed over this area. If you think of sound intensity as *force/area*, such as dynes per square centimeter, you can see how the increasing spherical area causes intensity to diminish accordingly.

For those unafraid of a little math, the difference in SPL at one distance, $D1$, and a reference distance, $D2$, is equal in decibels to

$$\text{dB} = -10 \times \log(D1/D2)$$

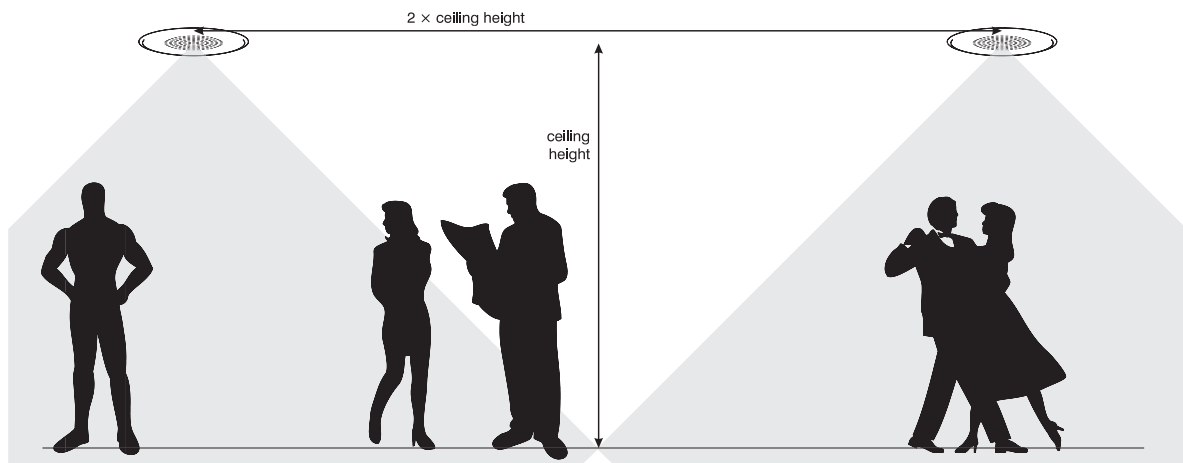

A better technique is to space the ceiling speakers at twice the distance from the listeners' ears to the ceiling. This requires more loudspeakers spaced closer together but provides greater intelligibility through better, more uniform coverage at realistic listening positions. In a room where people are standing, you'll need a little closer spacing than if they are sitting, simply because their ears are closer to the ceiling. For example, a company lunchroom needs a sound system; it has a ceiling height of 2.9 meters (9.5 ft), and you determine the height of an average listener's ear, when seated, is about 1.1 meter (3.5 ft) above the floor. That puts the ceiling-to-ear distance at about 1.8 meters (6 ft); therefore, you should space the loudspeakers no more than 3.6 meters (12 ft) apart.

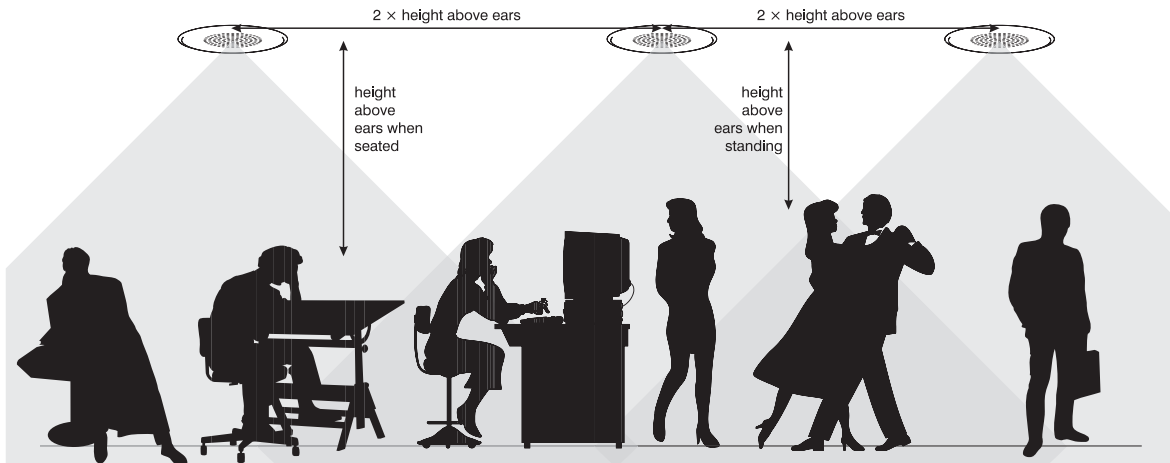

Better, more uniform coverage will result from spacing the loudspeakers at 1.5 times the ceiling-to-ear distance. In the lunchroom example, this would require spacing the loudspeakers about 2.7 meters (9 ft) apart.

Some manufacturers now offer ceiling loudspeakers with dispersion angles much wider than 90 degrees. These allow greater spacing between speakers, and consequently it takes fewer of them to cover the same area, although each one will require more power.

Determining power levels

After you've determined where to place the loudspeakers, you need to calculate the power each one requires. Background music will require an SPL at least 10 dB above the ambient noise. For good paging intelligibility, you'll need an SPL approximately 15 dB higher than the ambient noise; 25 dB above ambient will yield excellent intelligibility. If the installation is in an existing facility already in use, use an SPL meter, set for slow response, to measure the A-weighted ambient noise at several typical listening positions. Try to take this measurement at the

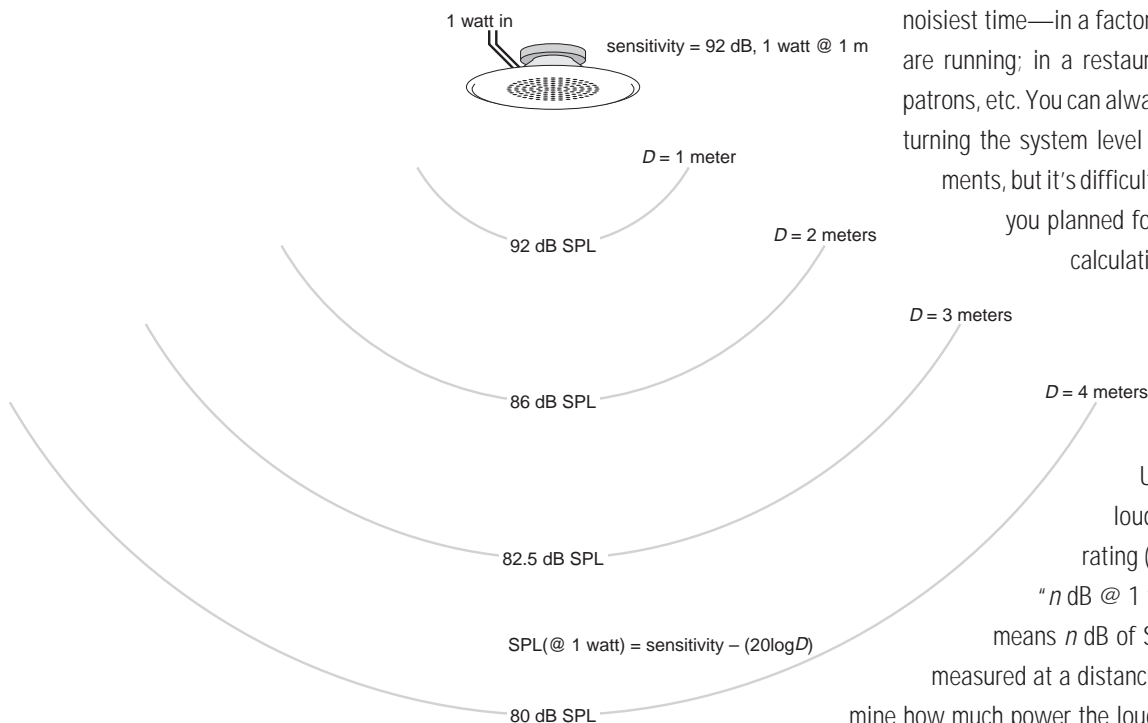

noisiest time—in a factory, when the machines are running; in a restaurant, when it's full of patrons, etc. You can always make provisions for turning the system level down for quieter moments, but it's difficult to get more level than you planned for, without a major re-calculation of equipment needs.

Next, measure the distance, D , in meters from the loudspeaker to the listeners' ears.

Use D along with the loudspeaker's sensitivity rating (typically expressed as " n dB @ 1 watt, 1 meter," which

means n dB of SPL with 1 watt input, measured at a distance of 1 meter) to determine how much power the loudspeaker needs to get

from the distributed line. Use the formula

$$dB = 20 \times \log D$$

or the Inverse Square guide below to convert distance-related attenuation to dB; you'll need to add this figure to the desired SPL and then subtract the sensitivity rating to determine how much more or less than 1 watt the loudspeaker requires.

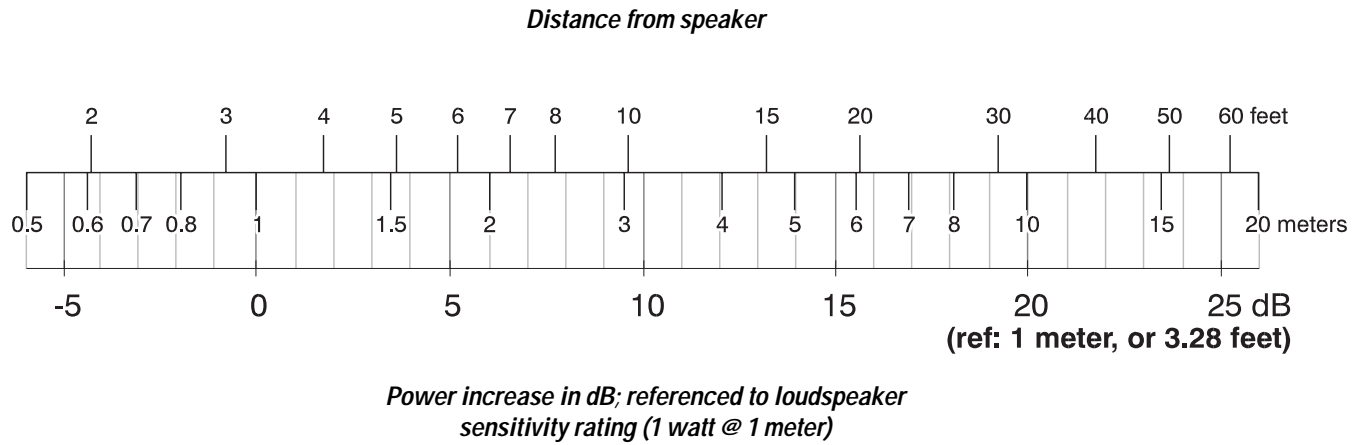

Calculating the necessary power is simple addition and subtraction if you use dBW, a decibel reference to watts in which 0 dBW = 1 watt. This is useful because the sensitivity spec already uses a reference of 1 watt. Then you can use the formula

$$\text{Power (in dBW)} = (\text{desired SPL}) + (\text{distance attenuation}) - (\text{speaker sensitivity})$$

To convert dBW to watts, use the graph at right or the formula

$$\text{Power (watts)} = 10^{(\text{dBW}/10)}$$

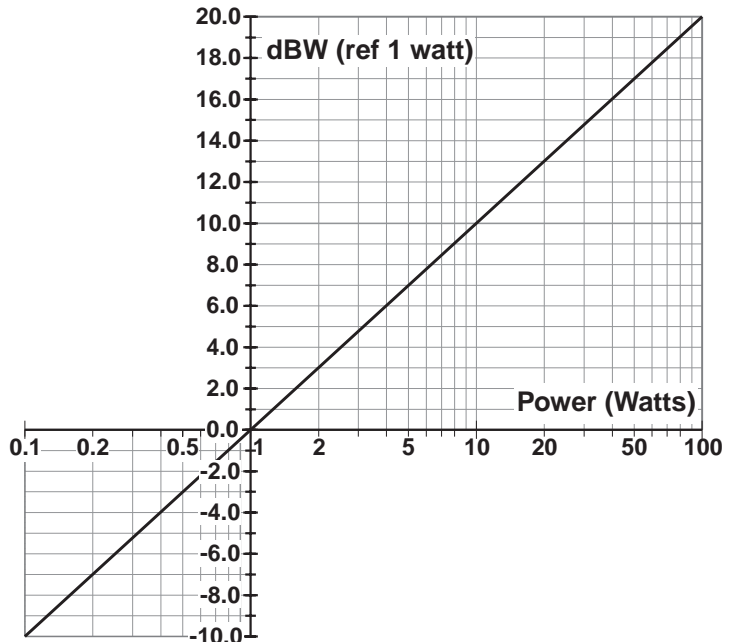

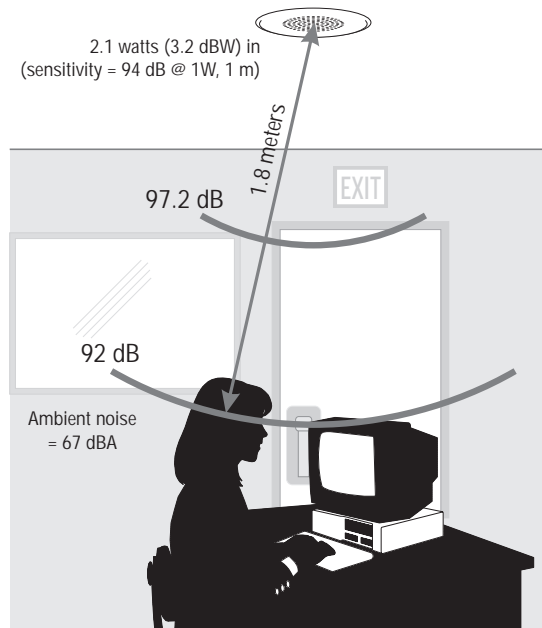

EXAMPLE

A loudspeaker (sensitivity: 94 dB @ 1W, 1 meter) in a busy office covers an area with an ambient noise level of 67 dBA, measured at a seated person's ear position at the desks. The client wants superb intelligibility, so your goal is to provide an SPL of 92 dB (25 dB above ambient SPL) to the intended listeners, the office workers. The ceiling-mounted speaker is about 6 feet, or 1.8 meters, from the workers' ears. The attenuation for D of 1.8 meters is 5.2 dB; this means that the loudspeaker would have to produce 97.2 dB (92 plus 5.2) at a distance of 1 meter to achieve 92 dB at a distance of 1.8 meters.

The loudspeaker will require a power level of 3.2 dBW (97.2 minus 94); this works out to 2.1 watts. The speaker transformer taps are 0.5, 1, 2, 4, and 8 watts; the closest choice would be the 2-watt tap, an almost exact match.

Calculating total power requirements

After you've determined the power taps for each loudspeaker transformer on the distributed line, add them up. The sum will be a start toward calculating the amplifier power requirements. If you have 16 loudspeakers tapped at 2 watts, seven at 1 watt, and eight at 10 watts, the total audio power the loudspeakers want is 119 watts.

Thanks to a transformer phenomenon called insertion loss, though, your amplifier actually needs to provide more power than the loudspeakers will get. High-quality speaker transformers typically have an insertion loss of about 1 dB or less, meaning that it takes as much as 1.25 watt going into the transformer to put 1 watt into the loudspeaker. A lower-quality transformer may have a loss of 2 dB, which requires approximately 1.6 watts for every watt that the loudspeaker receives. Poor-quality transformers may have even higher losses, but they will probably degrade the system's audio performance severely even if you allow extra amplifier power to overcome the losses.

To compensate for the insertion loss, add a corresponding percentage to the sum of the transformer power taps. For transformers with a 1 dB loss, add about 25%; in the example above, that would increase 119 watts up to 149 watts. To compensate for lesser-quality transformers with insertion losses of 1.5 dB and 2 dB, add 40% and 58%, respectively, to their individual power tap figures. Therefore, even with medium-quality speaker transformers, it could easily take up to 188 watts to provide 119 watts to the speakers! The sum of the power taps, corrected for insertion loss, is the distributed line's total power demand.

Fitting amplifier power

Choose an amplifier model whose power rating meets or exceeds the distributed line's total power demand. If it is a 70-volt line, use the per-channel power ratings of the CX-V direct 70-volt models (CX 302V, CX 602V, or CX 1202V). **Hint:** It is a good engineering practice to add up to 25% to the line power demand figure, to allow a margin both for dynamic audio headroom and for some future adjustments to the system—an added speaker or two, a few transformer tap changes, etc.

Use the CX302 with the IT-42 isolation transformer accessory for these applications:

- for 25-volt lines up to 300 watts
- for 70-volt lines up to 400 watts that require isolation
- for 100-volt lines up to 400 watts
- for a 140-volt line up to 800 watts (with the amp in bridged mono mode)
- for a 200-volt line up to 800 watts (with the amp in bridged mono mode)

Question: Like other QSC amps, the CX models carry two types of power ratings, EIA and FTC. The EIA ratings are specified at 1 kHz, at no more than 1% THD. The FTC ratings are more stringent, measured over a wide specified frequency range with THD not exceeding 0.05%. Which should you use?

Answer: Use the FTC spec for sound systems with a high duty cycle, i.e., operating at or near full power for extended periods of time. Some foreground music systems fall into this category. Use the EIA 1 kHz spec for systems with a light to moderate duty cycle, such as paging and announcing systems or combination background music/paging systems.

Using components with different line voltages

Sometimes it may be practical to use a transformer or loudspeaker/transformer combination with a different voltage system from what it was originally intended. For example, a 70-volt transformer could be used in a 25-volt system, although you would have to derate the power taps similarly. But never use a transformer with a higher voltage than what it is designed for; i.e., you couldn't use that same transformer on a 100- or 140-volt line.

		Voltage Rating of Transformer				
		50	70	100	140	200
Voltage of System	25	-6 dB	-9 dB	-12 dB	-15 dB	-18 dB
	50		-3 dB	-6 dB	-9 dB	-12 dB
	70			-3 dB	-6 dB	-9 dB
	100				-3 dB	-6 dB
	140					-3 dB

To properly derate the transformer tap power levels, use the chart at left. Locate the column with the voltage the transformer is rated for, then locate the row with the system voltage you want to use it in. The table will indicate the dB reduction to use with the derating chart below.

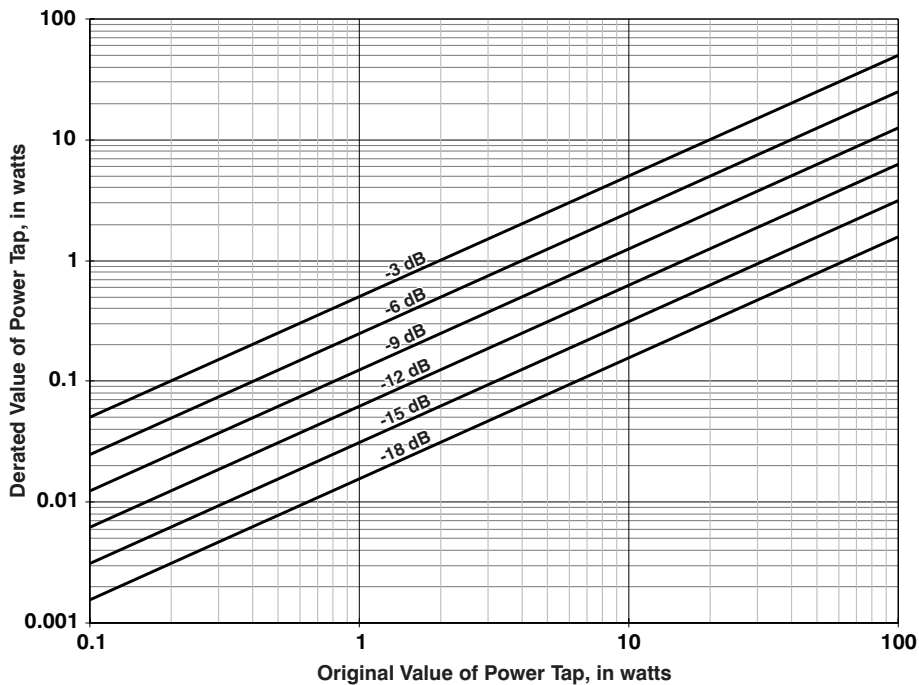

EXAMPLE

You have a 70-volt transformer with taps labeled 1, 2, 4, and 8 watts. What power points will those taps provide on a 25-volt line?

The table shows that 25 volts is 9 dB less than 70 volts. The chart confirms that the taps will provide 0.125, 0.25, 0.5, and 1 watt, respectively.

Sample applications & output configurations

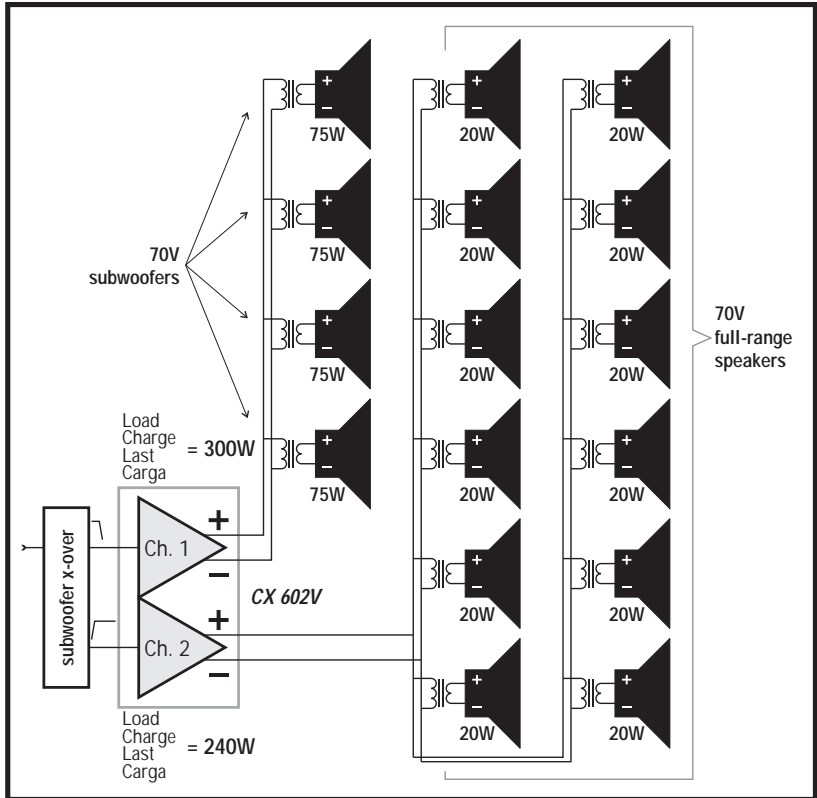

A CD megastore 70V system, with subwoofers

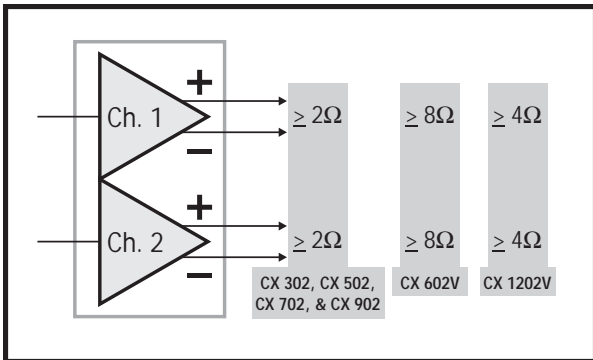

Minimum loading, stereo & parallel modes

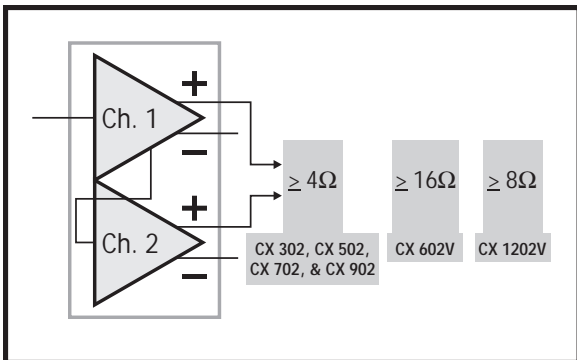

Minimum loading, bridged mono mode

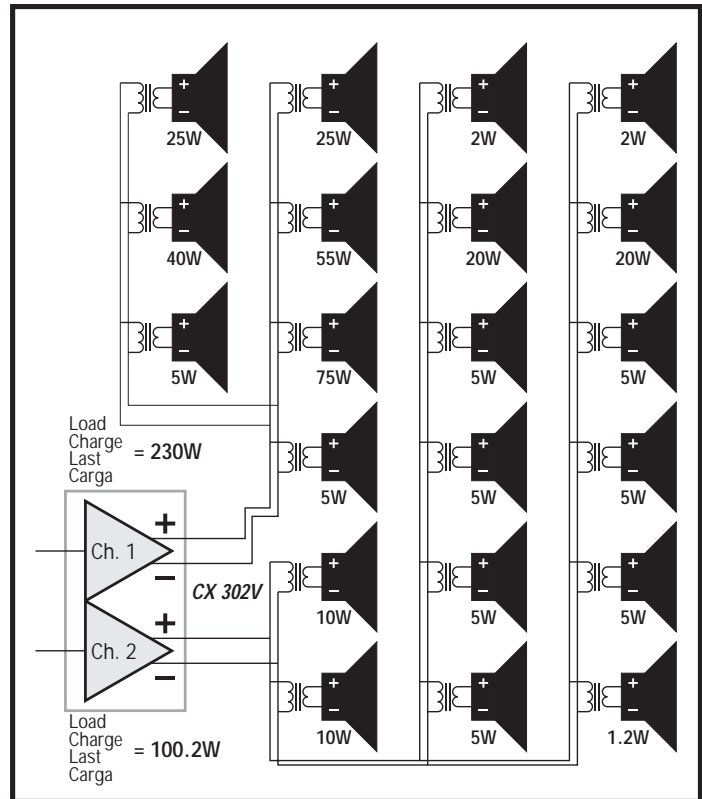

A 2-zone 70V system

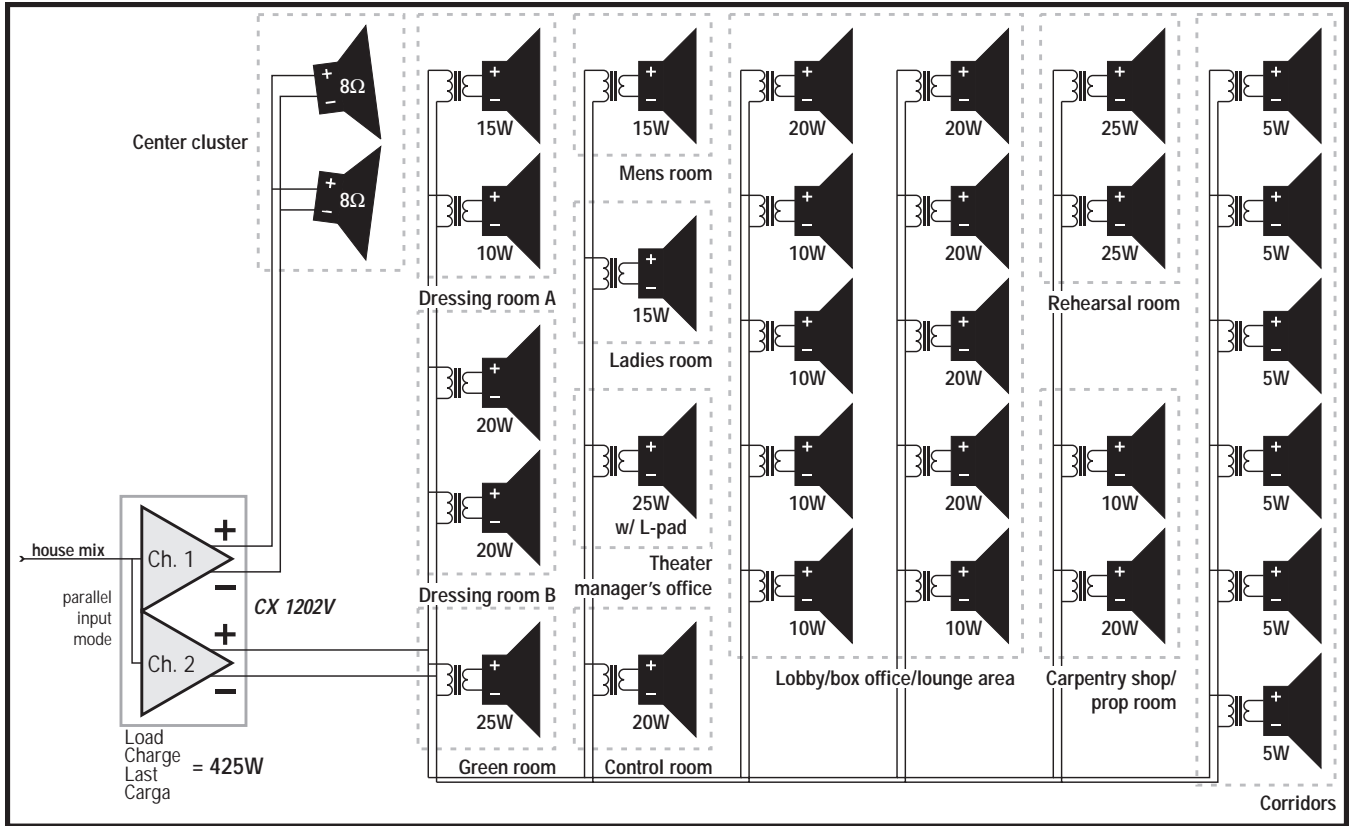

House system for a small theater

Other design considerations

Speaker transformer saturation

Speaker transformers tend to be fairly small and can vary widely in quality. Many are thus prone to core saturation at low frequencies, which occurs when the magnetic field induced in the transformer's iron core by the audio signal waveform reaches the limit the core can handle. Even if the instantaneous current increases in the primary windings, the magnetic flux in the core cannot, so it "clips," in a way. High frequencies generally reverse the direction of the magnetic flux well before saturation occurs, so they are of much less concern.

Saturation causes audible distortion, but in rare yet extreme cases it can also damage the power amplifier driving the line: as the transformers go out of saturation, their magnetic fields collapse and induce a large voltage spike across the line. That voltage spike travels along the line back to the amplifier, which has to absorb it. Interestingly, this phenomenon is much more likely to happen on a lightly loaded line than on a heavily loaded one.

Besides using larger, more expensive transformers of higher quality, an effective way to prevent saturation is to filter out the frequencies most likely to cause it without adversely affecting the audio quality. The CX models have user-selectable built-in high-pass filters; the "V" models offer 12 dB-per-octave rolloffs at 50 or 75 Hz, while the "non-V" models offer 33 or 75 Hz. The input filters can also be switched off, but we recommend that only if there is adequate filtering in the signal path before the amp. The amplifiers' filters are adequate saturation prevention for virtually all good-quality speaker transformers. However, if any speaker transformers on the line do not have low-frequency responses at least as low as 75 Hz, you must insert corresponding high-pass filtering in the audio signal path before the amplifier.

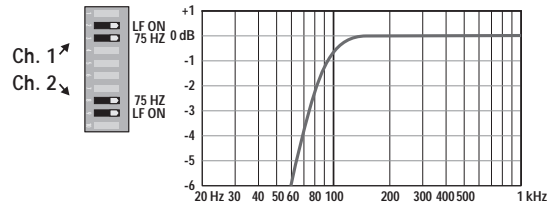
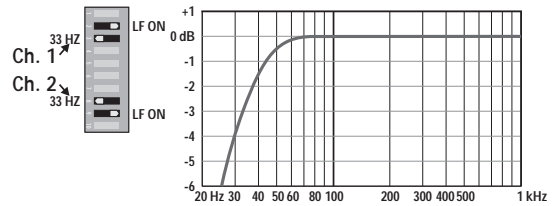
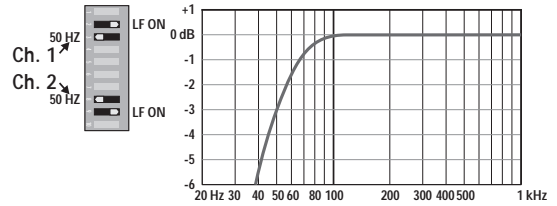
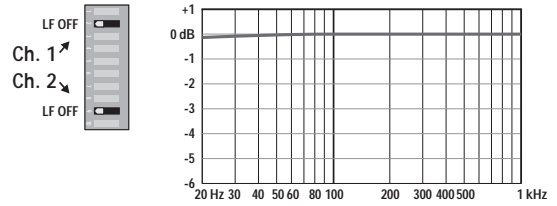

INSTALLATION TIP:

Once the sound system is installed and operational, turn the amplifier off and take an impedance measurement across the distributed line at the amplifier output, using an audio impedance meter (*not* an ohmmeter). Record the measurement for later use. If you ever have to make a service call on the system, measure the impedance again and see how it compares to the recorded figure; it's a quick and easy way to see if anything in the distributed line system has been changed. Likewise, measure and record the impedance anytime you've

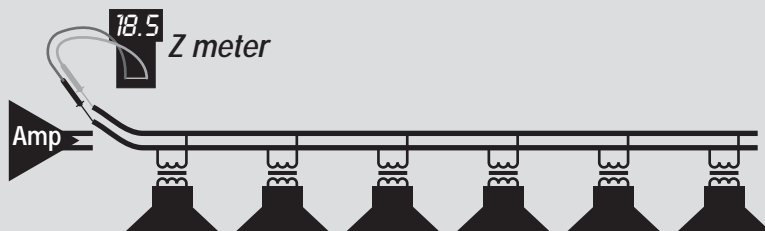

changed a transformer tap, added or removed a loudspeaker, or made any other adjustment to anything on the distributed line.

Speaker wire loss

A wire's resistance is inversely proportional to the cross-sectional area of its conductor, but even the highest-quality copper wire has some amount of resistance to electrical current flow. Therefore, to minimize the power lost to speaker cable resistance, you should use the largest stranded (always stranded) copper wire that is practical for the job. This is especially important with direct low-impedance speaker connections; e.g., a half-ohm wire resistance would not affect a lightly-loaded 100-volt line noticeably, but it would reduce the amount of power going to a 2-ohm load by 36%, a 1.9 dB drop. It would also reduce the damping factor to no better than 4.

If an amplifier could drive a speaker load through theoretical zero-resistance wire, no power would be lost in the speaker cables. In the charts below we'll compare the power delivered through real-world speaker cables with the theoretical zero-resistance ideal and express it as a ratio called the power transfer coefficient. It is determined by the formula

$$POWER\ TRANSFER\ COEFFICIENT = [R_{LOAD} / (R_{WIRE} + R_{LOAD})]^2$$

Let's say you have an 8-ohm speaker load. With that imaginary zero-resistance wire, all the power would be delivered to the load, so the power transfer coefficient would be 1. If you then substituted wire with 0.2 ohm of resistance, the load would only get 95.2% of the power it got with the zero-ohm wire, so the power transfer coefficient would be 0.952 (a loss of 0.2 dB, by the way).

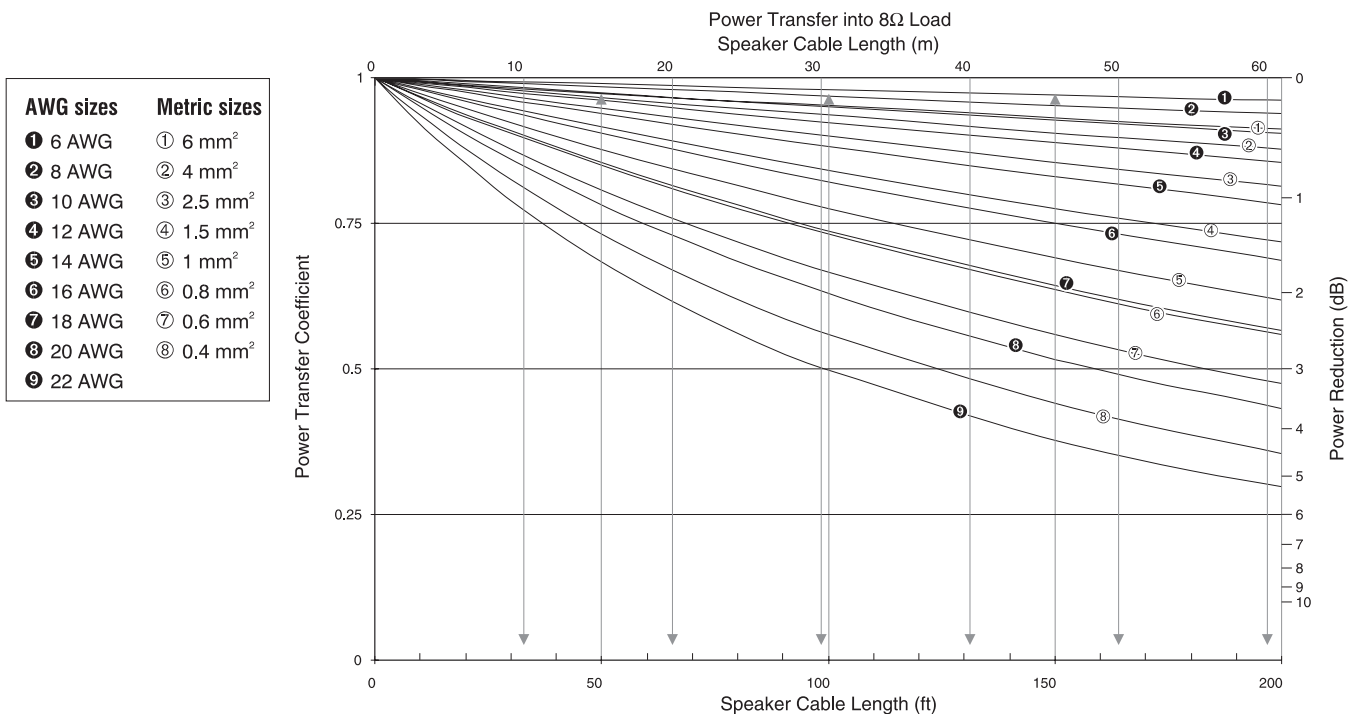

AC current consumption

A major objective in the design of the CX Series amplifiers—even the higher-powered models—is to permit their operation from readily available, standard AC power sources. Actual current consumption will depend on the amp model, the power level it is operating at, and the load impedances.

“Normal conditions” in power amplifier ratings means operating with a random program source (pink noise), at an average power level equal to one-eighth of maximum power. This is recognized by most of the world’s safety agencies as approximating the loudest level you can play music through an amplifier and still keep the incidence of clipping to a reasonable and inaudible minimum. An amplifier’s peak current draw at full output power into 2 ohms is several times what the “normal” draw is, but its various protection circuits will prevent this condition from lasting more than a minute or two.

When you plan the AC power hookups for your amplifiers, use this table to predict the current requirements per amplifier. You can use the one-eighth power figures to predict the normal continuous current draw, then add a safety margin to allow for occasional crescendos.

	Load	Idle	1/8 Power (pink noise)	1/3 Power (pink noise)	Full Power (sine)
CX302	8Ω + 8Ω	0.8 A	3.8 A	5.4 A	8.4 A
	4Ω + 4Ω	0.8 A	6.0 A	8.9 A	14 A
	2Ω + 2Ω	0.8 A	9.6 A	14.3 A	23 A
CX502	8Ω + 8Ω	0.9 A	5.6 A	8.0 A	12.5 A
	4Ω + 4Ω	0.9 A	9.0 A	13.3 A	21 A
	2Ω + 2Ω	0.9 A	14 A	21 A	34 A
CX702	8Ω + 8Ω	0.9 A	5.0 A	8.4 A	15.8 A
	4Ω + 4Ω	0.9 A	7.9 A	13.5 A	26 A
	2Ω + 2Ω	0.9 A	11.8 A	22 A	42 A
CX902	8Ω + 8Ω	0.9 A	6.0 A	11 A	20 A
	4Ω + 4Ω	0.9 A	9.5 A	17 A	33 A
	2Ω + 2Ω	0.9 A	14 A	27 A	50 A
CX 1102	8Ω + 8Ω	0.9 A	7.6 A	13.1 A	25 A
	4Ω + 4Ω	0.9 A	11.6 A	20 A	39 A
	2Ω + 2Ω	0.9 A	16.6 A	30 A	
CX302V	70V + 70V	0.8 A	5.7 A	8 A	16 A
CX602V	70V + 70V	0.9 A	8.7 A	13 A	21 A
CX1202V	70V + 70V	0.9 A	12 A	19 A	39 A

POWER CONSUMPTION NOTES

- “Idle” represents amplifier operation with signal levels 40 dB below full power or lower. Power consumption in *standby* mode is less than 5 watts.
- 1/8 power with pink noise represents typical program with occasional clipping, or the approximate highest output level before clipping becomes audible. Use this rating for most operation.
- 1/3 power with pink noise represents severe program with heavy clipping. This is an absolute worst case scenario, and approximates music played at absolute maximum level just short of total obliteration by clipping. This might be encountered in dance clubs and other scenarios where impact is more important than fidelity of sound. To avoid overheating, do not use load impedances lower than 4 ohms per channel (non-“V” models) or lines loaded at higher than 50% of the amp rating (“V” models).
- Full power measurements are with a continuous sine wave at 1% clipping. This would be encountered only in bench testing or driving a continuous signal such as a siren. In normal operation, full-power peaks are usually brief and rarely more than a 25% duty cycle. Continuous full-power operation is generally possible at the lightest loading (8 ohms per channel for non-“V” models; 50% loading for “V” models). This rating shows peak AC consumption and performance in unusual applications.
- Thermal or overcurrent cutback limits duration of full-power operation at heaviest load (2Ω or 100% load) after several seconds, and at half load (4Ω or 50% load) after several minutes.

Thermal losses (heat emissions)

Essentially, a power amplifier draws electrical energy from the AC mains, converts it to DC, and then converts it again into an analog of the input signal to power the loudspeakers. Power that enters the amplifier through the AC cord, less that which exits through the speaker outputs, is lost and turns into heat, called *thermal loss*. The amplifier must remove the heat to the outside surrounding space to prevent overheating. The amount of heat loss will depend on the amp model, the power level at which it is operated, and its load impedances.

The table of thermal loss specifications below will allow you to predict the heat produced by an amplifier system under various conditions and then specify adequate room cooling (e.g., air conditioning) to compensate. Use one-eighth power (the highlighted column) for normal, continuous usage. CX Series amplifiers are fan cooled, with rear-to-front air flow to avoid heat buildup in the equipment rack. They are designed to produce continuous 1/8 average power or better into the heaviest loads shown, in ambient temperatures of 35° C (95° F).

	Load	Idle		1/8 Power (pink noise)		1/3 Power (pink noise)		Full Power (sine)	
		BTU/hr	kcal/hr	BTU/hr	kcal/hr	BTU/hr	kcal/hr	BTU/hr	kcal/hr
CX 302	8Ω + 8Ω	200	50	565	145	720	180	715	180
	4Ω + 4Ω	200	50	995	250	1245	315	1295	325
	2Ω + 2Ω	200	50	1740	440	2255	570	2425	610
CX 502	8Ω + 8Ω	165	40	910	230	1130	285	1090	275
	4Ω + 4Ω	165	40	1570	395	1945	490	1875	475
	2Ω + 2Ω	165	40	2560	645	3470	875	3585	905
CX 702	8Ω + 8Ω	200	50	790	200	1080	275	1245	315
	4Ω + 4Ω	200	50	1310	330	1910	480	2320	585
	2Ω + 2Ω	200	50	2255	570	3190	805	4610	1160
CX 902	8Ω + 8Ω	220	55	900	225	1415	355	1705	430
	4Ω + 4Ω	220	55	1525	385	2560	645	3070	775
	2Ω + 2Ω	220	55	2305	580	4265	1075	5835	1470
CX 1102	8Ω + 8Ω	225	57	1195	300	1760	445	2050	515
	4Ω + 4Ω	225	57	2135	540	2335	590	3755	945
	2Ω + 2Ω	225	57	3975	1000	5210	1315		
CX 302V	70V + 70V	200	50	1125	285	1295	325	1080	270
CX 602V	70V + 70V	165	40	1785	450	2260	570	2055	520
CX 1202V	70V + 70V	200	50	2175	550	2605	655	4230	1065

THERMAL LOSS NOTES

- "Idle" represents amplifier operation with signal levels 40 dB below full power or lower. Thermal losses in *standby* mode are less than 17 Btu/hr (4.3 kcal/hr).
- 1/8 power with pink noise represents typical program with occasional clipping, or the approximate highest output level before clipping becomes audible. Use this rating for most operation.
- 1/3 power with pink noise represents severe program with heavy clipping. This is an absolute worst case scenario, and approximates music played at absolute maximum level just short of total obliteration by clipping. This might be encountered in dance clubs and other scenarios where impact is more important than fidelity of sound. To avoid overheating, do not use load impedances lower than 4 ohms per channel (non-"V" models) or lines loaded at higher than 50% of the amp rating ("V" models).
- Full power measurements are with a continuous sine wave at 1% clipping. This would be encountered only in bench testing or driving a continuous signal such as a siren. In normal operation, full-power peaks are usually brief and rarely more than a 25% duty cycle. Continuous full-power operation is generally possible at the lightest loading (8 ohms per channel for non-"V" models; 50% loading for "V" models). This rating shows peak AC consumption and performance in unusual applications.
- Thermal or overcurrent cutback limits duration of full-power operation at heaviest load (2Ω or 100% load) after several seconds, and at half load (4Ω or 50% load) after several minutes.

Thermal losses (heat emissions)

Essentially, a power amplifier draws electrical energy from the AC mains, converts it to DC, and then converts it again into an analog of the input signal to power the loudspeakers. Power that enters the amplifier through the AC cord, less that which exits through the speaker outputs, is lost and turns into heat, called *thermal loss*. The amplifier must remove the heat to the outside surrounding space to prevent overheating. The amount of heat loss will depend on the amp model, the power level at which it is operated, and its load impedances.

The table of thermal loss specifications below will allow you to predict the heat produced by an amplifier system under various conditions and then specify adequate room cooling (e.g., air conditioning) to compensate. Use one-eighth power (the highlighted column) for normal, continuous usage. CX Series amplifiers are fan cooled, with rear-to-front air flow to avoid heat buildup in the equipment rack. They are designed to produce continuous 1/8 average power or better into the heaviest loads shown, in ambient temperatures of 35° C (95° F).

	Load	Idle		1/8 Power (pink noise)		1/3 Power (pink noise)		Full Power (sine)	
		BTU/hr	kcal/hr	BTU/hr	kcal/hr	BTU/hr	kcal/hr	BTU/hr	kcal/hr
CX 302	8Ω + 8Ω	200	50	565	145	720	180	715	180
	4Ω + 4Ω	200	50	995	250	1245	315	1295	325
	2Ω + 2Ω	200	50	1740	440	2255	570	2425	610
CX 502	8Ω + 8Ω	165	40	910	230	1130	285	1090	275
	4Ω + 4Ω	165	40	1570	395	1945	490	1875	475
	2Ω + 2Ω	165	40	2560	645	3470	875	3585	905
CX 702	8Ω + 8Ω	200	50	790	200	1080	275	1245	315
	4Ω + 4Ω	200	50	1310	330	1910	480	2320	585
	2Ω + 2Ω	200	50	2255	570	3190	805	4610	1160
CX 902	8Ω + 8Ω	220	55	900	225	1415	355	1705	430
	4Ω + 4Ω	220	55	1525	385	2560	645	3070	775
	2Ω + 2Ω	220	55	2305	580	4265	1075	5835	1470
CX 1102	8Ω + 8Ω	225	57	1195	300	1760	445	2050	515
	4Ω + 4Ω	225	57	2135	540	2335	590	3755	945
	2Ω + 2Ω	225	57	3975	1000				
CX 302V	70V + 70V	200	50	1125	285	1295	325	1080	270
CX 602V	70V + 70V	165	40	1785	450	2260	570	2055	520
CX 1202V	70V + 70V	200	50	2175	550	2605	655	4230	1065

THERMAL LOSS NOTES

- "Idle" represents amplifier operation with signal levels 40 dB below full power or lower. Thermal losses in *standby* mode are less than 17 Btu/hr (4.3 kcal/hr).
- 1/8 power with pink noise represents typical program with occasional clipping, or the approximate highest output level before clipping becomes audible. Use this rating for most operation.
- 1/3 power with pink noise represents severe program with heavy clipping. This is an absolute worst case scenario, and approximates music played at absolute maximum level just short of total obliteration by clipping. This might be encountered in dance clubs and other scenarios where impact is more important than fidelity of sound. To avoid overheating, do not use load impedances lower than 4 ohms per channel (non-"V" models) or lines loaded at higher than 50% of the amp rating ("V" models).
- Full power measurements are with a continuous sine wave at 1% clipping. This would be encountered only in bench testing or driving a continuous signal such as a siren. In normal operation, full-power peaks are usually brief and rarely more than a 25% duty cycle. Continuous full-power operation is generally possible at the lightest loading (8 ohms per channel for non-"V" models; 50% loading for "V" models). This rating shows peak AC consumption and performance in unusual applications.
- Thermal or overcurrent cutback limits duration of full-power operation at heaviest load (2Ω or 100% load) after several seconds, and at half load (4Ω or 50% load) after several minutes.

System design with CX Series amplifiers



Left: a CX amplifier without its security cover installed



Right: a CX amplifier with its security cover installed

Model	Power, 8Ω/ch 20 Hz–20 kHz, 0.03% THD	Power, 4Ω/ch 20 Hz–20 kHz, 0.05% THD	Power, 2Ω/ch 1 kHz, 1% THD
CX 302	200 W	325 W	600 W
CX 502	300 W	500 W	800 W
CX 702	425 W	700 W	1200 W
CX 902	550 W	900 W	1500 W
CX 1102	700 W	1100 W	1700 W
Model	Power @ 70V 20 Hz–20 kHz, 0.05% THD	Power @ 70V 1 kHz, 1% THD	
CX 302V	200 W	300 W	
CX 602V	400 W	600 W	
CX 1202V	800 W	1200 W	

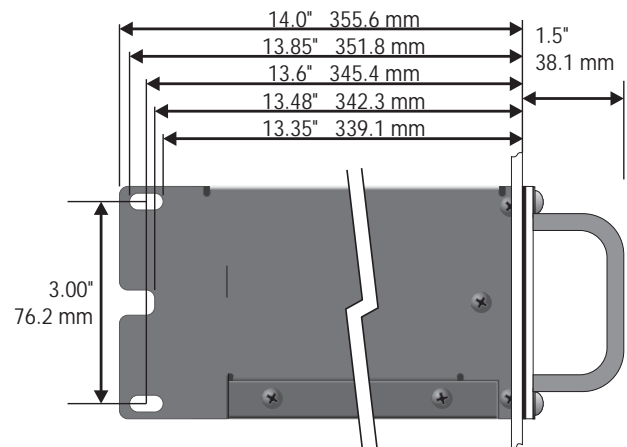

Specially designed for contractor and installed sound applications, the new **CX Series** amplifiers feature PowerWave™ switching supply technology for better regulation and to eliminate hum. A new-generation direct metal-mounted output section yields even lower distortion and higher current capacity, providing studio-quality performance with touring-quality reliability and lightweight in a strong, compact chassis.

The CX Series comprises eight 2-channel, 2 RU models. Five are low-impedance amplifiers, designed to drive loads of 8, 4, or 2 ohms per channel: **CX 302**, **CX 502**, **CX 702**, **CX 902**, and **CX 1102**. Into 8 and 4 ohms per channel, they are suitable for full-power operation even at full duty cycle. Into 2 ohms per channel, they are suitable for operation at full power at slightly reduced duty cycle.

Three models, designated by the letter “V” in the model number, are designed to drive 70-volt distributed lines directly, without output transformers: **CX 302V**, **CX 602V**, and **CX 1202V**. They can be bridged to drive 140-volt lines in mono. For critical operation or full duty cycle operations, the amps can drive line loads equivalent to the 20 Hz–20 kHz power ratings.

The “V” models can also drive low-impedance loads. See the power specs in the back of this manual for appropriate ratings.

Aside from the types of speaker systems they are designed to drive, some features and setup procedures differ between the low-impedance and “V” models.

Features

- Barrier strip output connectors
- Direct transformerless 70-volt outputs (“V” models)
- Zero inrush current—won’t trip circuit breakers at turn-on and avoids need for sequential power-up
- DataPort for use with QSCControl and amplifier accessories
- Independent, user-defeatable clip limiters
- Fully selectable low-frequency filtering; choice of 33 or 75 Hz roll-off or 50 or 75 Hz roll-off (“V” models)
- Stereo (dual-channel), parallel-input, or bridged mono operating modes
- Balanced inputs: XLR and “Euro-style” detachable terminal blocks
- Recessed, detented gain controls with security cover
- Front panel LED indicators for power, signal, -20 and -10 dB, clip/protect, parallel inputs, and bridged mono mode
- QSC’s exclusive high-performance PowerWave switching technology power supply
- Optional isolated output transformer pack IT-42 available for driving 2-channel 25-, 70-, and 100-volt lines, or 50, 140, and 200-volt lines in bridged mono (CX 302 only).

The inner workings

An impressive amount of technology is packed “under the hood” of a CX Series amplifier. Thousands of watts of power flow inches away from state-of-the-art low noise inputs. Precise circuit layout and thorough protection assure that all of this activity occurs smoothly and safely. So, what actually happens when you turn on the power switch?

Soft Start Sequence. The first task is to charge the primary energy reservoir without drawing a large surge current. A special inrush limiter allows just enough current to charge the energy bank in three seconds. Meanwhile, a low-power switching supply provides power to start up the main supply. After three seconds, a relay bypasses the inrush limiting and full power operation is enabled. The audio circuitry mutes for one second to eliminate start-up thumps. When the red **CLIP** lights go out, the amplifier is ready for action.

PowerWave™ Technology. High current switching devices draw over 10,000 watts of peak power from the main energy reservoir, which is replenished directly from the AC line for maximum stiffness. Conventional amplifiers must isolate the energy bank with a large AC transformer, which weakens the flow of current, allows greater sag under load, and produces hum. The PowerWave supply performs voltage conversion at a very high frequency, allowing better coupling through a much smaller isolation transformer.

High Performance Audio. High speed power transistors convert this DC power into the full range audio output which drives the speakers. High-current design and special dual-sense output feedback corrects errors on both sides of the speaker terminals, improving damping and control of speaker motion. The power devices are directly mounted to isolated heat sinks, which form a short, wide air tunnel in front of the fan for optimum cooling.

A thermal sensor embedded in each channel’s heat sink monitors the temperature and controls fan speed, thermal shutdown, and bias control, assuring maximum audio clarity at all temperatures and signal levels. A circuit monitors transistor dissipation and triggers protective cutback only when actually needed.

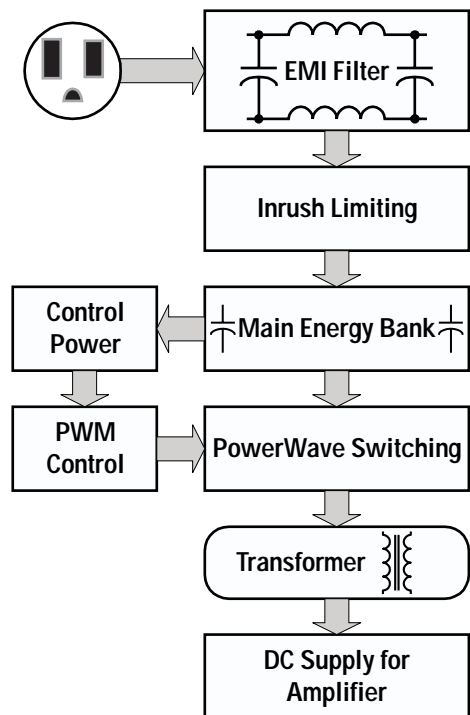

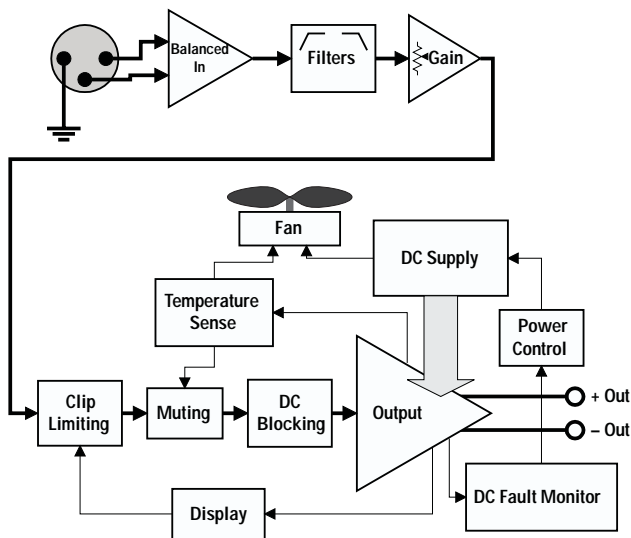

The output circuitry is actively clamped during clipping for smooth and very fast recovery. The clamp also feeds a proportional clip limiter, which actually senses the depth of clipping and responds accordingly.

The balanced inputs use premium 0.1% precision resistors for very high noise rejection. The precision components used in the input filters and all other circuitry ensure accurate performance.

Shutdown. The amplifier mutes as soon as power is shut off, preventing turn-off noises. Serious faults trigger a shutdown of the power supply; the high switching frequency cuts off power within microseconds to limit damage.

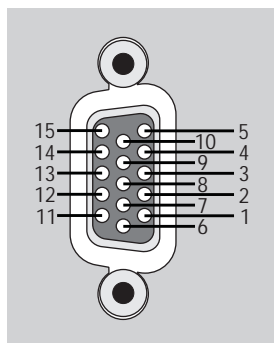

Exclusive CX features and accessories

DataPort

The amplifier features a DataPort, which connects to a QSCControl MultiSignal Processor or other QSC accessories via the HD-15 connector.

QSCControl is a QSC-exclusive system for remotely controlling and monitoring amplifiers and other equipment via an Ethernet-based data network and a personal computer. The operating software is easily customized using Microsoft Visual Basic.

DataPort pin identification

Remote on/off using the DataPort

Even if you don't use QSCControl or an accessory with the amplifier, you can use the DataPort to remotely switch one or more amplifiers on and off without having to switch AC currents. Shorting pin 2 of the DataPort to chassis ground places the power supply in standby, shutting off the amplifier circuitry. Removing the short allows the power supply to start up again, and the amplifier goes through its startup sequence. You can connect together pin 2 of several CX amplifiers in the same rack and switch this connection to chassis ground to use as a remote on/off. There is no surge of inrush current when turning on a CX amp, so there is no danger of tripping circuit breakers, and no need for sequential turn-on.

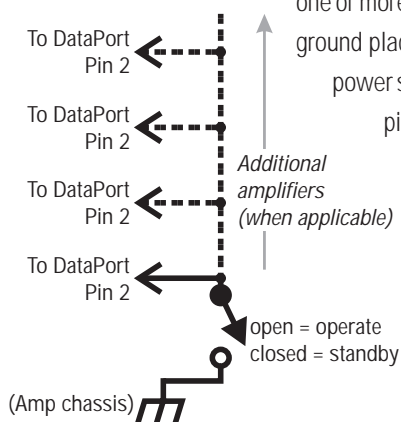

Remote on/off switching through the DataPort

Accessories

IT-42 isolation transformer pack

For applications requiring isolated 25-, 70-, or 100-volt outputs, the IT-42 (pictured at right), a unique transformer “backpack” accessory, allows the CX 302 to deliver up to 400 watts per channel or zone (300 watts on 25-volt lines). In bridged mono mode, it can be used to drive a single 140- or 200-volt line loaded at up to 800 watts. The IT-42 mounts to the back of the amplifier, but it doesn't interfere with cooling airflow or inhibit access to input and output connectors or to the amp's configuration switches.

The IT-42 is available from your QSC CX dealer or distributor or from QSC's Technical Services department (phone: 1-800-QSC AUDIO *toll-free in USA only*) or 1+ (714) 957-7150; e-mail: support@qscaudio.com).

For highest value and sound quality in music-oriented systems that don't require isolation, the transformerless “V” models are recommended for driving 70V lines.

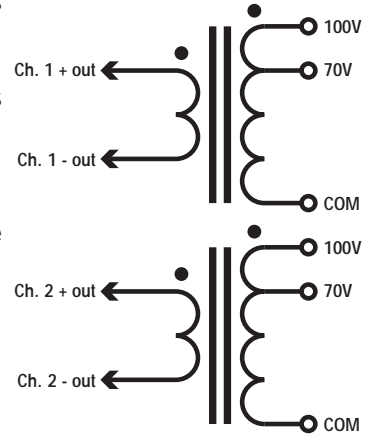
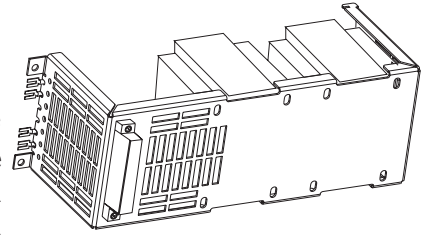

IT-42 schematic

Crossover and filter modules

Other accessories for the CX amplifiers include crossover and filter modules that mount directly to the rear panel of the amplifier, needing no additional rack space or external power.

These accessories include the XC-3, a 2-way crossover; the SF-3 Subwoofer Filter; and the LF-3 Low-Frequency filter. You can use these accessories in various combinations with your amplifiers to create 2-way, 3-way, and 4-way (3-way plus subwoofer) active systems. The XC-3 also features high-frequency boost and CD horn equalization.

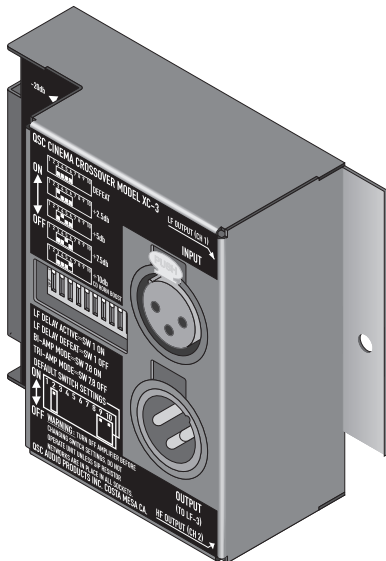

The XC-3 2-way crossover accessory. The LF-3 low frequency filter and SF-3 subwoofer filter accessories are similar.

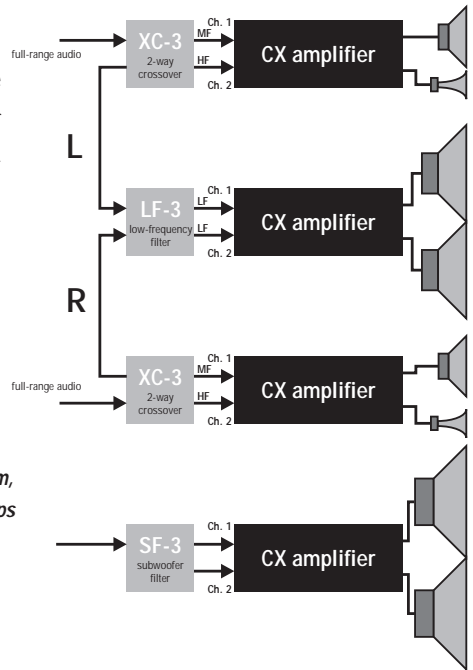

A stereo 3-way + subwoofer system, using four CX amps

A mono 2-way system using one CX amp

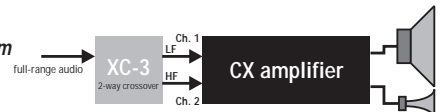

Front & rear panels

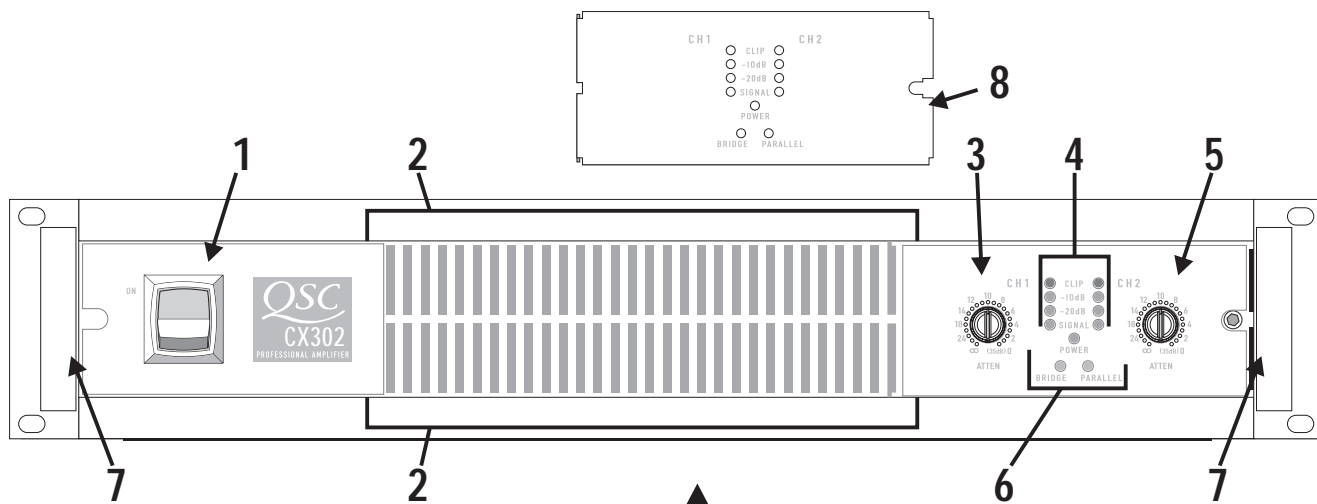

Front panel

1. Power switch
2. Cooling vents
3. Gain control (Channel 1)
4. **CLIP**, **-10 dB**, **-20 dB** and **SIGNAL** indicator LEDs, both channels
5. Gain control (Channel 2)
6. **POWER**, **BRIDGE**, and **PARALLEL** indicator LEDs
7. Handles (optional)
8. Security panel

Rear panel

1. Terminal block inputs, Channels 1 and 2
2. DataPort
3. XLR inputs, Channels 1 and 2
4. Configuration switch
5. Configuration switch chart
6. Barrier strip outputs, Channels 1 and 2
7. Cooling air inlet vents
8. Serial number label with AC voltage rating
9. IEC connector for AC power cable

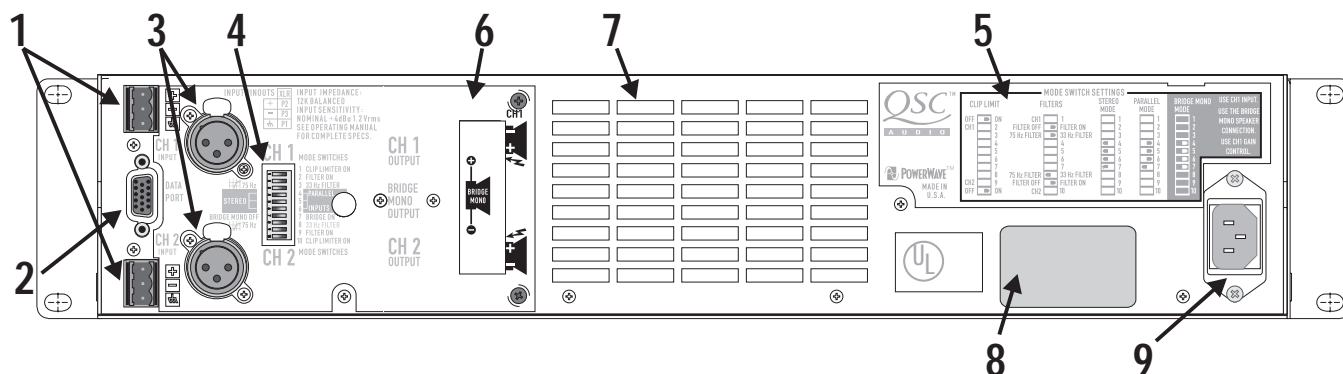

Specifications

	CX 302	CX 502	CX 702	CX 902	CX 1102
OUTPUT POWER in watts					
20 Hz–20 kHz @ 0.03% THD 8Ω per channel	200	300	425	550	700
20 Hz–20 kHz @ 0.05% THD 4Ω per channel	325	500	700	900	1100
EIA: 1 kHz @ 1% THD					
8Ω per channel	215	325	475	625	
4Ω per channel	375	550	825	1050	
2Ω per channel	600	800	1200	1500	1700
Bridge Mono:					
16Ω, 20 Hz–20 kHz, 0.1% THD	400	600	850	1100	1400
8Ω, 20 Hz–20 kHz, 0.1% THD	700	1000	1500	2000	2200
4Ω, 1 kHz, 1% THD	1200	1600	2400	3000	3400
DYNAMIC HEADROOM	2 dB @ 4Ω				
DISTORTION					
SMPTE-IM	< 0.01%	< 0.01%	< 0.02%	< 0.02%	< 0.02%
FREQUENCY RESPONSE	20 Hz–20 kHz, ±0.2 dB				
(at 10 dB below rated output power)	-3 dB points: 5 Hz and 100 kHz				
DAMPING FACTOR	> 500 @ 8Ω				
NOISE (unweighted 20 Hz to 20 kHz, below rated output)	106 dB	107 dB	106 dB	104 dB	106 dB
VOLTAGE GAIN	31.5× (30 dB)	40× (32 dB)	50.5× (34 dB)	56.6× (35 dB)	56.6× (35 dB)
INPUT SENSITIVITY, V_{RMS}					
full rated power @ 8Ω	1.26v (+4.2 dBu)	1.23v (+4.0 dBu)	1.16v (+3.5 dBu)	1.17v (+3.6 dBu)	1.35v (+4.8 dBu)
full rated power @ 4Ω	1.14v (+3.4 dBu)	1.12v (+3.2 dBu)	1.05v (+2.6 dBu)	1.06v (+2.7 dBu)	1.17v (+3.6 dBu)
INPUT CLIPPING, V_{RMS}	10v (+22.2 dBu)				
INPUT IMPEDANCE	6 KΩ unbalanced 12 KΩ balanced				
CONTROLS	Front: AC switch, Ch. 1 and Ch. 2 gain knobs with 21 detents Rear: 10-position DIP switch				
INDICATORS	POWER: Green LED		CLIP: Red LED, 1 per channel		
	PARALLEL: Yellow LED		-10 dB: Green LED, 1 per channel		
	BRIDGED: Yellow LED		-20 dB: Green LED, 1 per channel		
			SIGNAL: Green LED, 1 per channel		
CONNECTORS	Input: XLR, pin 2 positive; detachable "Euro-style" terminal blocks Output: Barrier strip				
COOLING	Forced-air, with fan speed fully variable from off to full; back-to-front air flow				
AMPLIFIER PROTECTION	Full short circuit, open circuit, thermal, ultrasonic, and RF protection Stable into reactive or mismatched loads				
LOAD PROTECTION	Turn-on/turn-off muting, DC-fault power supply shutdown, clip limiting				
OUTPUT CIRCUIT TYPE	AB	AB	H	H	H
	AB: Class AB complementary linear output H: Class AB complementary linear output with Class H 2-step high efficiency circuit				
DIMENSIONS	19.0" (48.3 cm) wide, 3.5" (8.9 cm) tall (2 rack spaces) 14.0" (35.6 cm) deep (rack mounting to rear support ears)				
WEIGHT	Shipping: 27 lbs (12.3 kg) Net: 21 lbs (9.5 kg)				
POWER REQUIREMENTS	Available for 120 or 220–240 VAC, 50/60 Hz				

Specifications

	CX 302V	CX 602V	CX 1202V
OUTPUT POWER in watts			
20 Hz–20 kHz @ 0.05% THD			
@ 70V	200	400	800
@ 8Ω per channel		550	700
@ 4Ω per channel			1100
EIA: 1 kHz @ 0.05% THD			
@ 70V	250	440	1000
EIA: 1 kHz @ 0.1% THD			
@ 70V	300	600	1200
Bridge Mono:			
140V, 20 Hz–20 kHz, 0.1% THD	400	800	850
140V, 1 kHz, 0.1% THD	600	1200	2400
16Ω, 20 Hz–20 kHz, 0.1% THD		1200	1400
8Ω, 20 Hz–20 kHz, 0.1% THD			2300
DYNAMIC HEADROOM	2 dB @ 4Ω		
DISTORTION			
SMPTE-IM	< 0.02%		
FREQUENCY RESPONSE			
(at 10 dB below rated output power)	20 Hz–20 kHz, ±0.2 dB		
	-3 dB points: 5 Hz and 100 kHz		
DAMPING FACTOR	> 500 @ 8Ω		
NOISE (unweighted 20 Hz to 20 kHz, below rated output)	106 dB		
VOLTAGE GAIN	56.6× (35 dB)		
INPUT SENSITIVITY, V_{RMS}			
full 70.7V output	1.26v (+4.2 dBu)		
INPUT CLIPPING, V_{RMS}	10v (+22.2 dBu)		
INPUT IMPEDANCE	6 KΩ unbalanced		
	12 KΩ balanced		
CONTROLS	Front: AC switch, Ch. 1 and Ch. 2 gain knobs with 21 detents		
	Rear: 10-position DIP switch		
INDICATORS	POWER: Green LED	CLIP: Red LED, 1 per channel	
	PARALLEL: Yellow LED	-10 dB: Green LED, 1 per channel	
	BRIDGED: Yellow LED	-20 dB: Green LED, 1 per channel	
		SIGNAL: Green LED, 1 per channel	
CONNECTORS	Input: XLR, pin 2 positive; detachable "Euro-style" terminal blocks		
	Output: Barrier strip		
COOLING	Forced-air, with fan speed fully variable from off to full; back-to-front air flow		
AMPLIFIER PROTECTION	Full short circuit, open circuit, thermal, ultrasonic, and RF protection		
	Stable into reactive or mismatched loads		
LOAD PROTECTION	Turn-on/turn-off muting, DC-fault power supply shutdown, clip limiting		
OUTPUT CIRCUIT TYPE	AB	AB	H
	AB: Class AB complementary linear output		
	H: Class AB complementary linear output with Class H 2-step high efficiency circuit		
DIMENSIONS	19.0" (48.3 cm) wide, 3.5" (8.9 cm) tall (2 rack spaces)		
	14.0" (35.6 cm) deep (rack mounting to rear support ears)		
WEIGHT	Shipping: 27 lbs (12.3 kg) Net: 21 lbs (9.5 kg)		
POWER REQUIREMENTS	Available for 120 or 220–240 VAC, 50/60 Hz		

Address & telephone information

**Address:**

QSC Audio Products, Inc.
1675 MacArthur Boulevard
Costa Mesa, CA 92626-1468 USA

**Telephone Numbers:**

Main Number (714) 754-6175

Sales Direct Line (714) 957-7100

Sales & Marketing

(800) 854-4079

(toll-free in U.S.A. only)

Technical Services (714) 957-7150

(800) 772-2834

(toll-free in U.S.A. only)

**Facsimile Numbers:**

Sales & Marketing FAX
(714) 754-6174

Technical Services FAX
(714) 754-6173

**BBS/World Group:**

QSC OnLine Technical Support
1200-14400 bps; 8N1
(714) 668-7567
(800) 856-6003

CompuServe

GOQSCAUDIO
ID: 76702,2635

World Wide Web

<http://www.qscaudio.com>



www.qscaudio.com

1675 MacArthur Boulevard Costa Mesa, California 92626 USA • PH: (714) 754-6175 FAX: (714) 754-6174

"CX" and "PowerWave" are trademarks of QSC Audio Products, Inc. "QSC" and the QSC logo are registered with the U.S. Patent and Trademark Office
©1996, 1999 QSC Audio Products, Inc.