

**Structural Certification**  
Install Line Array (ILA)

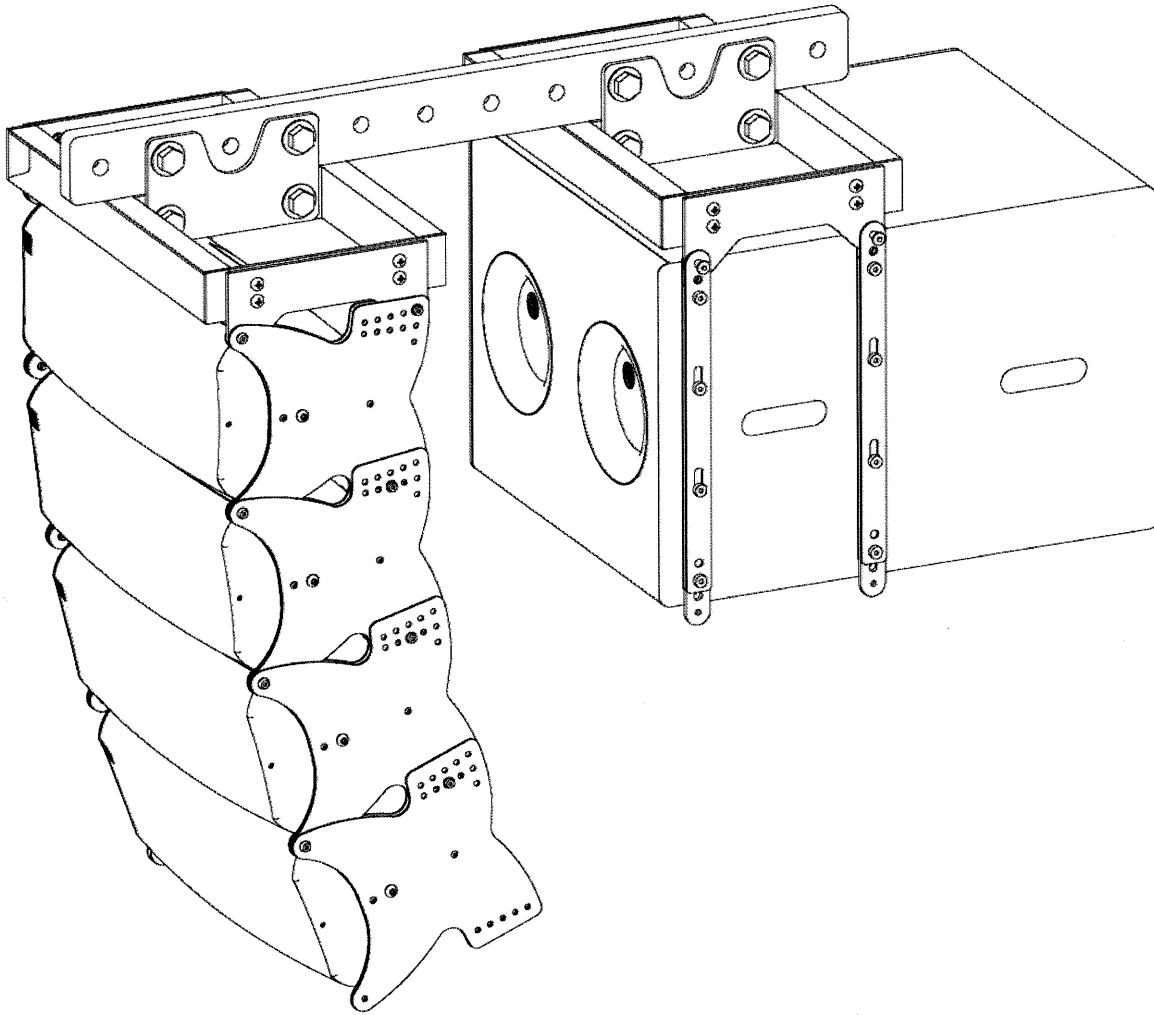



**CONTENTS:**

- 1.0** Approvals
- 2.0** Revision History
- 3.0** Objective
- 4.0** Working Load Limits And Design Factors
- 5.0** Nomenclature
- 6.0** Certification Of Component Working Load Limits
  - 6.1 WL2082-i Loudspeaker
  - 6.2 WL115-sw Loudspeaker
  - 6.3 FB2082-i Array Frame
  - 6.4 EB2082-i Extension Bar
  - 6.5 PB2082-i Pull Back Bar
- 7.0** Fastener Testing
- 8.0** ILA Test Results Summary

**1.0 APPROVALS****Structural Certification**

<b>PRODUCT</b>	ILA
<b>REVISION</b>	A
<b>DATE ISSUED</b>	11-13-06

Originated by:  Date: 11-13-06

Steve Tamasi  
Mechanical Engineer  
Loudspeaker R&D

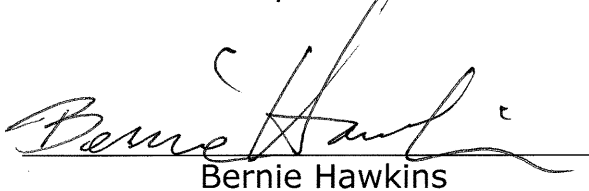
Review by:  Date: 11/13/06

Bernie Hawkins  
R&D Manager, Loudspeakers  
Loudspeaker R&D

Review by:  Date: 11-13-06

Mark Engebretson  
VP R&D / Chief Systems Architect  
R&D

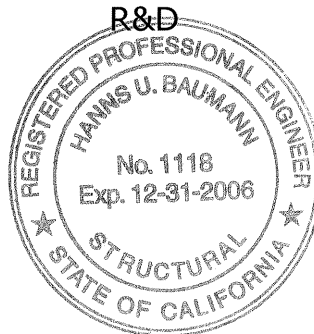

Certified by:  Date: 11/14/06

Hanns Baumann  
Registered Professional Engineer  
BAUMANN ENGINEERING



### 3.0 OBJECTIVE

This document contains information that is required for ILA Structural Certification.

### 4.0 WORKING LOAD LIMITS AND DESIGN FACTORS

Table 1 lists the ILA suspension components and provides Working Load Limit data at various Design Factors. The tabulated Design Factors are for static loads only. The choice of which Design Factor to use will depend upon the jurisdiction and venue of installation, as well as the conditions of suspension. Dynamic conditions are determined by unknown, installation-specific factors and should be referred to a Licensed Structural Engineer for clarification before proceeding with any suspension of the equipment. The data presented is based upon the listed component weights:

**Table 1: ILA Working Load Limits**

Component	Weight	5:1 Design Factor	7:1 Design Factor	10:1 Design Factor
EB2082-i Extension Bar	38 lb (17.3 kg)	2400 lb(1090.0 kg)	1714 lb (779.2 kg)	1200 lb (545.5 kg)
FB2082-i Array Frame	17 lb (7.7 kg)	1036 lb (470.9 kg)	740 lb (336.4 kg)	518 lb (235.5 kg)
PB2082-i Pull Back Bar	6 lb (2.7 kg)	296 lb (134.5 kg)	211 lb (96.1 kg)	148 lb (67.3 kg)
WL2082-i Loudspeaker	37 lb (16.8 kg)	889 lb (403.2 kg)	634 lb (288.3 kg)	445 lb (201.8 kg)
WL115-sw Loudspeaker	111 lb (50.5 kg)	1036 lb (470.9 kg)	740 lb (336.4 kg)	518 lb (235.5 kg)
M8 Shoulder Bolt <sup>1</sup>	not applicable	1404 lb (638.2 kg)	1003 lb (455.8 kg)	702 lb (319.1 kg)
M8 Ball-lock Pin <sup>1</sup>	not applicable	2534 lb (1151.8 kg)	1810 lb (822.7 kg)	1267 lb (575.9 kg)
M12 Shoulder Bolt <sup>1</sup>	not applicable	6641 lb (3018.8 kg)	4744 lb (2156.3 kg)	3321 lb (1509.4 kg)
3/8" Fastener <sup>1</sup>	not applicable	2721 lb (1236.7 kg)	1943 lb (883.4 kg)	1360 lb (618.4 kg)
7/8" Fastener <sup>1</sup>	not applicable	11354 lb (5161.0 kg)	8110 lb (3686.4 kg)	5677 lb (2580.5 kg)

1- Working Load Limits are per fastener loaded in double shear. Data is for informational purposes only.

### 5.0 NOMENCLATURE

The terms "ILA", "Installation Line Array", "CLA" & "Compact Line Array" all refer to the same product and may be used interchangeably.

**6.0 CERTIFICATION OF COMPONENT WORKING LOAD LIMITS**

The individual suspension components shown in Table 1 are to be structurally validated through testing. Five (5) different samples of each component are to withstand a load at least ten (10) times greater than the Working Load Limit (WLL) at a 10:1 Design Factor shown in Table 1. For example, the FB2082-i Array Frame must withstand a load of not less than 5,180 lbs (518 lbs x 10).

The test loads are to be applied in a manner outlined later in this document. This will recreate some of the worst case loading scenarios that the components could foreseeable encounter under normal use assuming safe rigging practices are utilized.

All test are to be conducted and results fully documented per ISO 17025 (General requirements for the competence of testing and calibration laboratories).

**Test Results Summary**

See summary at end of report of samples tested, WLL requirements and test report information.

**Lab Test Reports**

See copy of test reports for additional testing details.

**Material Certificates**

Material Certificates have been obtained for all samples. Certificates are also obtained for all production rigging components as material verification. See enclosed material certificates for information on samples tested.

**6.1 WL2082-i LOUDSPEAKER**

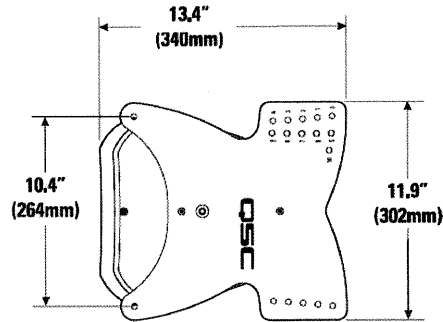
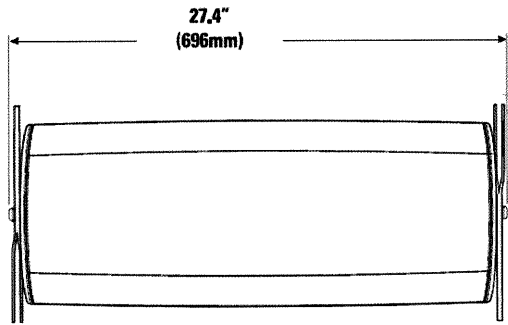

**Test Information**

Component Name: CH-000468-XX & CH-000469-XX  
 Material: Aluminum 6061-T6  
 WLL: The test requirement will be 1/2 the WLL as the loading is distributed over (2) sets of rigging plates.  
 Test Name: CLA-TEST-01B-PLATES  
 CLA-TEST-02-PLATES  
 CLA-TEST-03-PLATES  
 CLA-TEST-04-PLATES  
 CLA-TEST-05-PLATES  
 Test Description: 2 point pull, rear holes  
 (Note that test number 01B to 05 all apply to rear holes and will be considered interchangeable for certification purposes.)  
 Test Name: CLA-TEST-06-PLATES  
 Test Description: 2 point pull, front holes

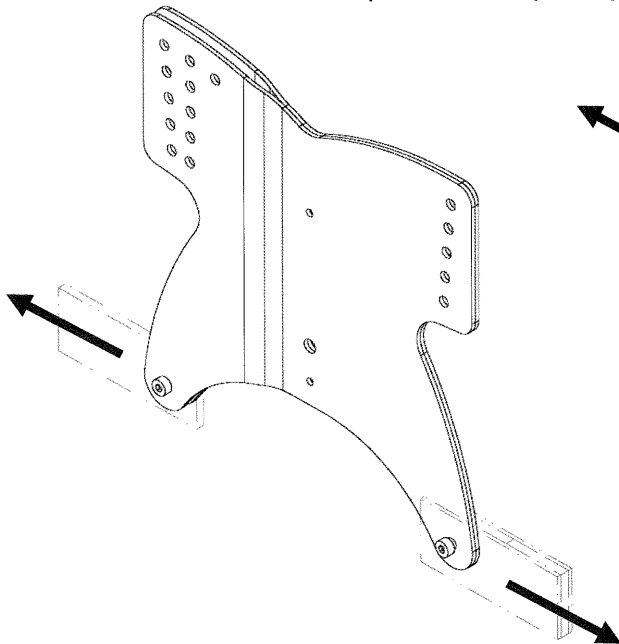

**CLA-TEST-06-PLATES** – Front holes

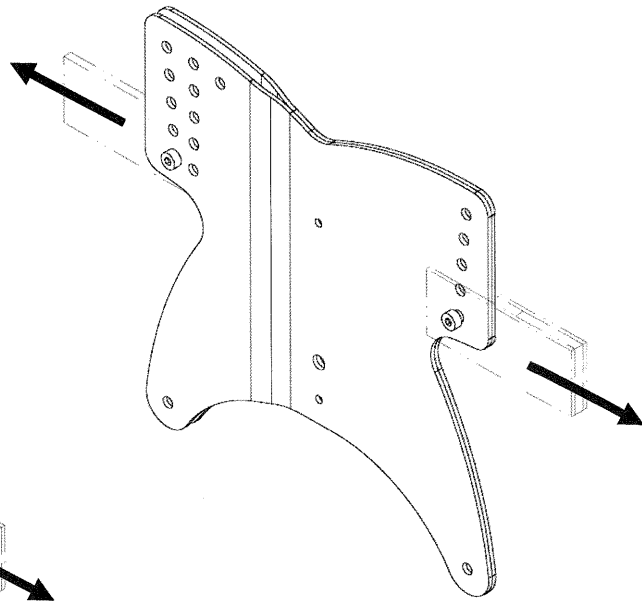

**CLA-TEST-04-PLATES** – rear holes

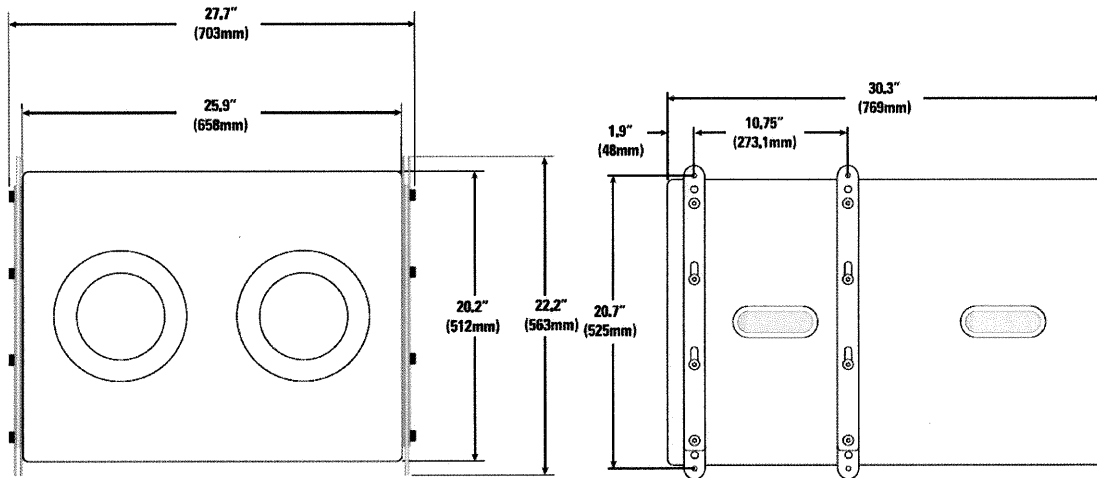
**6.2 WL115-sw LOUDSPEAKER****Test Information**

Component Name: CH-000470-XX & CH-000472-XX  
Material: Aluminum 6061-T6  
WLL: The test requirement will be ½ the WLL as the loading is distributed over (2) sets of rigging straps.  
Test Name: CLA-TEST-08-SUB  
Test Description: 2 point pull

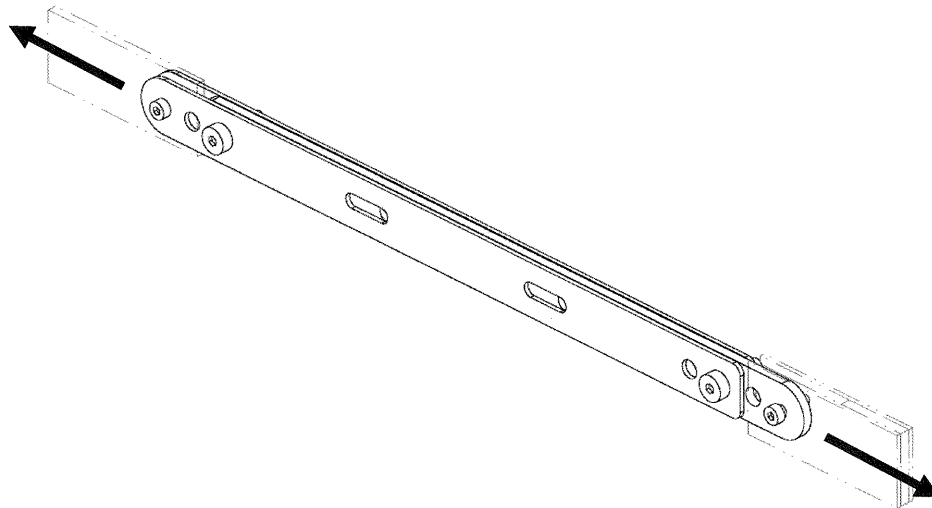
**CLA-TEST-08-SUB**

**6.3 FB2082-i ARRAY FRAME**

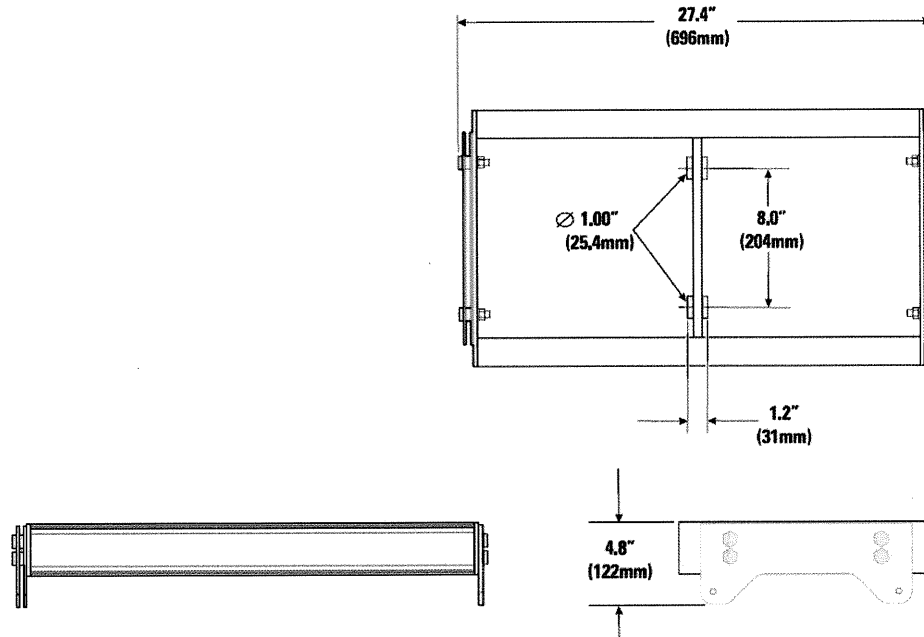

**Test Information**

Component Name: CH-000480-XX  
 Material: Aluminum 6061-T6  
 Test Name: CLA-TEST-11-FLYGRID  
 Test Description: 3 point pull

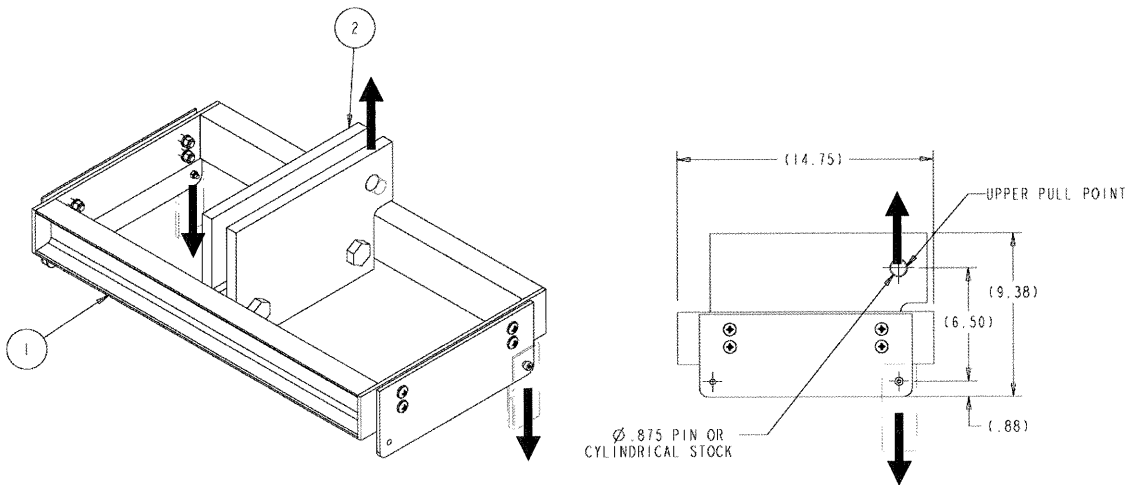

**TEST 11**

**6.4 EB2082-i EXTENSION BAR**

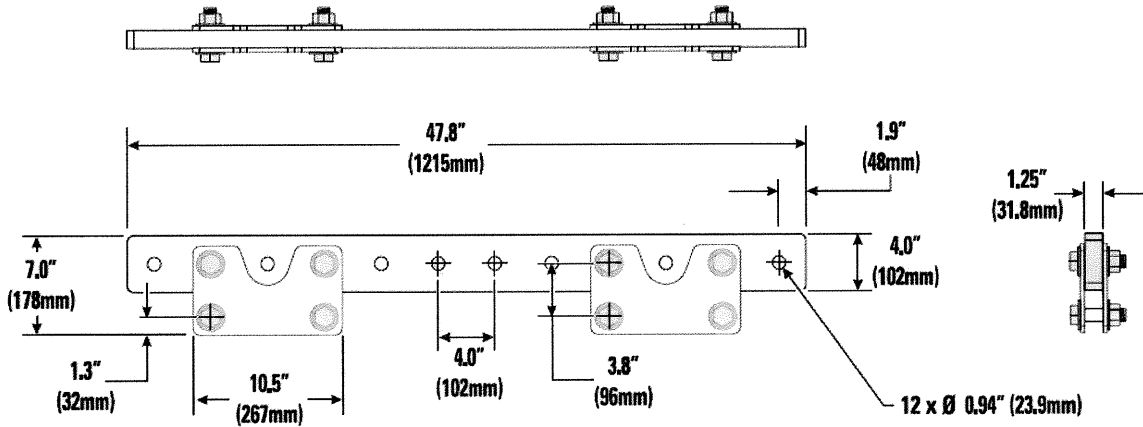

**Test Information**

Component Name: CH-000503-XX  
 Material: Aluminum 6061-T6  
 Test Name: CLA-TEST-12-EXTENSION  
 Test Description: 3 point pull

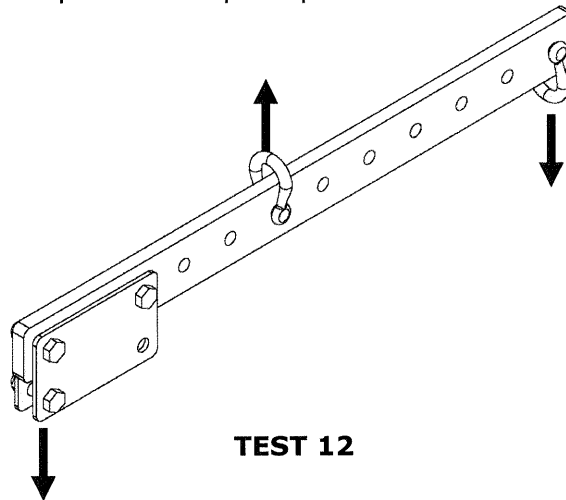

**6.5 PB2082-i PULL BACK BAR**

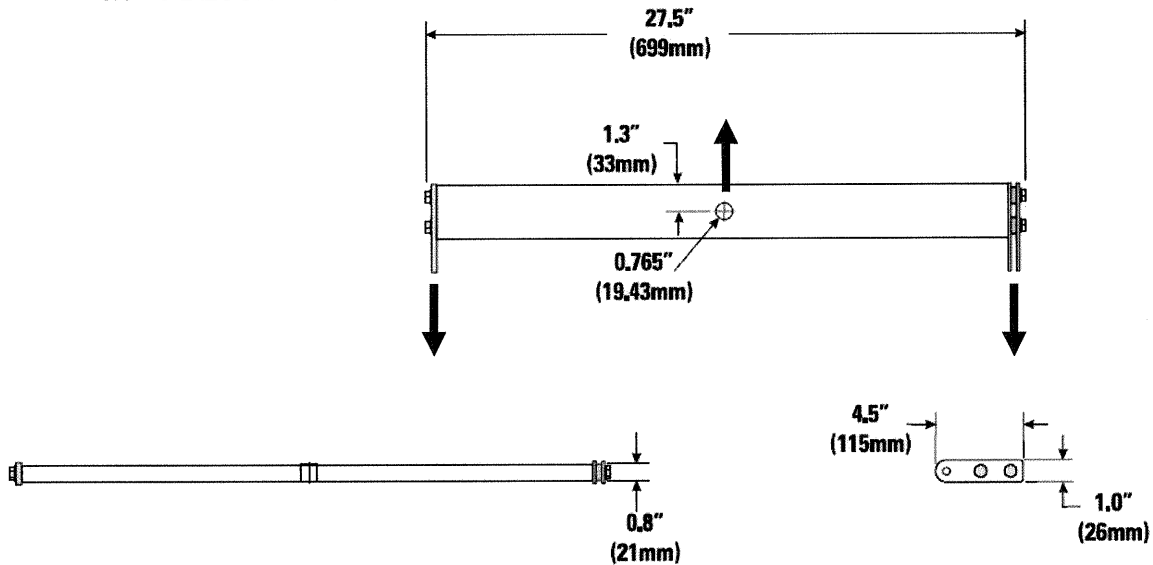

**Test Information**

Component Name: CH-000504-XX  
 Material: Aluminum 6061-T6  
 Test Name: CLA-TEST-17-PULLBACK  
 Test Description: 3 point pull

**7.0 FASTENER TESTING**

Fasteners that do not already have an existing grade or class rating will be subject to a double-shear test. Due to the high breaking strength of the fasteners, they will be subject to a proof load of at least ten (10) times the maximum working load. The fasteners may not necessarily be tested to the ultimate breaking strength. The following fasteners will be subject to testing:

Component Name/Material:

- M8 SHOULDER SCREW (SC-000075-XX), Stainless Steel
- M8 SHOULDER SCREW (SC-000123-00), Alloy Steel
- M8 BALL LOCK PIN (HW-000099-00), Steel
- M8 LOCKING PLATE (CH-000580-01), Steel
- M12 SHOULDER SCREW (SC-000076-00), Steel

Test Name: CLA-TEST-22-SHEAR  
 Test Description: double shear test

The following fasteners will not be tested as they already have existing minimum strength ratings, based on the grade or class of the fastener.

- SCREW, M8, FLAT HEAD, 30 MM L, CLASS 10.9
- 7/8" Fastener - SCREW, HEX, 7/8-9, 3.0 L, GRADE 5
- 3/8" Fastener - SCREW, 3/8 (no longer used in product)



Hear the Power of Technology

1675 MacArthur Blvd., Costa Mesa, CA 92626  
Phone 714.754.6175 Fax 714.754.6174**8.0 TEST RESULTS SUMMARY**

COMPONENT / TEST NAME:	RUN NO:	SAMPLE NO:	REQUIRED WLL (LBS):	DATE TESTED:	REPORT NO:	MAX LOAD APPLIED (lbs):	PROOF / ULTIMATE:	DESIGN FACTOR TESTED:
<b>WL2082-i LOUDSPEAKER, rear holes (CH-000468-XX &amp; CH-000469-XX)</b>								
CLA-TEST-01B-PLATES	1	1 & 2	223	12/05/05	252075	6,129	ULT	27.5
CLA-TEST-02-PLATES	2	5 & 6	223	12/13/05	252155	2,706	PROOF	12.2
CLA-TEST-03-PLATES	3	7 & 8	223	12/13/05	252155	2,707	PROOF	12.2
CLA-TEST-04-PLATES	4	9 & 10	223	12/13/05	252155	2,712	PROOF	12.2
CLA-TEST-05-PLATES	5	11 & 12	223	12/13/05	252155	2,708	PROOF	12.2
<b>WL2082-i LOUDSPEAKER, front holes (CH-000468-XX &amp; CH-000469-XX)</b>								
CLA-TEST-06-PLATES	1	3 & 4	223	12/05/05	252075	6,127	ULT	27.5
CLA-TEST-06-PLATES	2	104 & 105	223	09/29/06	261725	3,770	ULT	16.9
CLA-TEST-06-PLATES	3	106 & 107	223	09/29/06	261725	3,580	ULT	16.1
CLA-TEST-06-PLATES	4	108 & 109	223	09/29/06	261725	3,595	ULT	16.2
CLA-TEST-06-PLATES	5	110 & 111	223	09/29/06	261725	3,830	ULT	17.2
<b>WL115-sw LOUDSPEAKER, rigging strap (CH-000470-XX &amp; CH-000472-XX)</b>								
CLA-TEST-08-SUB	1	13	259	01/17/06	252142	3,222	PROOF	12.4
CLA-TEST-08-SUB	2	14	259	01/17/06	252142	3,276	PROOF	12.6
CLA-TEST-08-SUB	3	16	259	09/29/06	261725	7,908	ULT	30.5
CLA-TEST-08-SUB	4	78	259	09/29/06	261725	8,275	ULT	31.9
CLA-TEST-08-SUB	5	79	259	09/29/06	261725	8,161	ULT	31.5
<b>FB2082-i ARRAY FRAME (CH-000480-XX)</b>								
CLA-TEST-11-FLYGRID	1	100	518	07/29/06	261213	5,740	PROOF	11.1
CLA-TEST-11-FLYGRID	2	101	518	07/29/06	261213	12,374	ULT	23.9
CLA-TEST-11-FLYGRID	3	113	518	09/29/06	261725	9,910	ULT	19.1
CLA-TEST-11-FLYGRID	4	114	518	09/29/06	261725	10,077	ULT	19.5
CLA-TEST-11-FLYGRID	5	115	518	09/29/06	261725	12,555	ULT	24.2
<b>EB2082-i EXTENSION BAR (CH-000503-XX)</b>								
CLA-TEST-12-EXTENSION	1	49	1200	09/29/06	261725	18,987	ULT	15.8
CLA-TEST-12-EXTENSION	2	50	1200	01/25/06	260127	20,014	ULT	16.7
CLA-TEST-12-EXTENSION	3	51	1200	09/29/06	261725	19,725	ULT	16.4
CLA-TEST-12-EXTENSION	4	52	1200	01/25/06	260127	20,028	ULT	16.7
CLA-TEST-12-EXTENSION	5	144	1200	10/05/06	261725A	19,981	ULT	16.7
<b>PB2082-i PULL BACK BAR (CH-000504-XX)</b>								
CLA-TEST-17-PULLBACK	1	102	148	07/29/06	261213	1,651	PROOF	11.2
CLA-TEST-17-PULLBACK	2	103	148	07/29/06	261213	6,606	ULT	44.6
CLA-TEST-17-PULLBACK	3	119	148	09/29/06	261725	6,606	ULT	44.6
CLA-TEST-17-PULLBACK	4	120	148	09/29/06	261725	6,505	ULT	44.0
CLA-TEST-17-PULLBACK	5	121	148	09/29/06	261725	6,641	ULT	44.9



Hear the Power of Technology

1675 MacArthur Blvd., Costa Mesa, CA 92626  
Phone 714.754.6175 Fax 714.754.6174

COMPONENT / TEST NAME:	RUN NO:	SAMPLE NO:	REQUIRED WLL (LBS):	DATE TESTED:	REPORT NO:	MAX LOAD APPLIED (lbs):		DESIGN FACTOR TESTED:
<b>M8 SHOULDER SCREW (SC-000075-XX) from Elytone *</b>								
M8 SHOULDER SCREW	1	88	259	10/25/06	261791	9,685	ULT	37.4
M8 SHOULDER SCREW	2	89	259	10/25/06	261791	9,695	ULT	37.4
M8 SHOULDER SCREW	3	122	259	10/25/06	261791	9,601	ULT	37.1
M8 SHOULDER SCREW	4	123	259	10/25/06	261791	9,699	ULT	37.4
M8 SHOULDER SCREW	5	124	259	10/25/06	261791	9,717	ULT	37.5
<b>M8 SHOULDER SCREW (SC-000123-00) domestic *</b>								
M8 SHOULDER SCREW	1	125	259	10/25/06	261791	12,113	ULT	46.8
M8 SHOULDER SCREW	2	126	259	10/25/06	261791	12,138	ULT	46.9
M8 SHOULDER SCREW	3	127	259	10/25/06	261791	10,989	ULT	42.4
M8 SHOULDER SCREW	4	128	259	10/25/06	261791	12,399	ULT	47.9
M8 SHOULDER SCREW	5	129	259	10/25/06	261791	10,965	ULT	42.3
<b>M8 BALL LOCK PIN (HW-000099-00) *</b>								
M8 BALL LOCK PIN	1	90	259	10/25/06	261791	14,675	PROOF	56.7
M8 BALL LOCK PIN	2	91	259	10/25/06	261791	10,031	PROOF	38.7
M8 BALL LOCK PIN	3	130	259	10/25/06	261791	11,061	PROOF	42.7
M8 BALL LOCK PIN	4	131	259	10/25/06	261791	11,539	PROOF	44.6
M8 BALL LOCK PIN	5	132	259	10/25/06	261791	11,035	PROOF	42.6
<b>M8 LOCKING PLATE (CH-000580-01) *</b>								
M8 LOCKING PLATE	1	133	259	10/25/06	261791	10,150	ULT	39.2
M8 LOCKING PLATE	2	134	259	10/25/06	261791	9,599	ULT	37.1
M8 LOCKING PLATE	3	135	259	10/25/06	261791	9,701	PROOF	37.5
M8 LOCKING PLATE	4	136	259	10/25/06	261791	9,259	PROOF	35.7
M8 LOCKING PLATE	5	137	259	10/25/06	261791	9,276	PROOF	35.8
<b>M12 SHOULDER SCREW (SC-000076-00) *</b>								
M12 SHOULDER SCREW	1	92	259			9,000	PROOF	34.7
M12 SHOULDER SCREW	2	93	259			9,000	PROOF	34.7
M12 SHOULDER SCREW	3	138	259			9,000	PROOF	34.7
M12 SHOULDER SCREW	4	139	259			9,000	PROOF	34.7
M12 SHOULDER SCREW	5	140	259			9,000	PROOF	34.7

\* Fastener test data is provided for informational purposes only.