

Preliminary



KLA Series

Fixed Arcuate Active Line Array System

Features of the KLA12

- 500 W x 500 W power module
- Rugged, ABS enclosure delivers light-weight durability
- SOLO™ Rigging System supports deployment without tools or external hardware
- Ar-Q™ Frequency Optimization quickly tunes the array with the click of a dial, adjusting for the appropriate number of boxes
- 12:1 design factor supports arrays of up to five (5) units
- 90° x 18° nominal coverage (requires only five boxes to configure a 90° x 90° array)
- High power, 12" low-frequency driver provides extension down to 44Hz without subwoofers
- Extensive DSP further enhances and protects performance
- 1.75" diaphragm compression driver delivers clear and powerful, high-frequency reproduction
- PowerCON® Input and Thru connections
- Tilt-Direct™ pole mount assists directivity in single-unit applications

Features of the KLA181

- 1,000 watt power module
- 18" vented subwoofer
- High acoustic output (135 dB SPL peak)
- Frequency range down to 33 Hz (-10 dB)
- Extensive DSP further enhances and protects performance
- PowerCON® Input and Thru connections
- Threaded pole-cup receptacle for free-standing applications
- Suspension made possible via M10 fittings or KLA12AF Array Frame
- Integrated threaded pole mount supports up to two KLA12 enclosures

The KLA Series brings the power and sophistication of a line array system into an easy-to-use product; significantly redefining the line array product category. With its simple Lift, Click and Play approach, KLA can be deployed in a fraction of the time required by comparable line array products. This fixed arcuate, active line array system is ideal for a wide range of portable and permanently installed applications ranging from live entertainment to houses of worship or other venues where a line array system is desired.

KLA Power Module

The KLA Series is comprised of two models, the KLA12 12-inch, 2-way loudspeaker and the KLA181 an 18-inch subwoofer. The KLA12 features a highly efficient 500 W x 500 W power amp module and the KLA181 offers the same highly efficient power amp module in a 1,000 W configuration. This efficient design enables

KLA12 | KLA181



up to five KLA models (any combination of KLA12 and KLA181) to be driven off of a single 15 amp/120 V electrical circuit. KLA loudspeakers incorporate QSC's DEEP™ DSP algorithm, providing extended bass response by actively managing potentially damaging low-frequency transients, and GuardRail™ circuitry protection which prevents the amplifier module from unnatural and destructive clipping. As an energy saving feature, the Auto Standby mode automatically engages after five minutes of inactivity but upon resumption of audio signal, the power module on the KLA will awaken instantly for immediate output.



In an installed application, multiple KLA Series loudspeakers can be "daisy-chained" for total gain control from a single remote pot wired to the on-board Phoenix-style connector. Additional power module characteristics on KLA include a balanced, line-level XLR input in parallel with an XLR "Thru" connector, powerCON® In and Thru connectors, Attenuation Control and LED indicators for Signal, Limit, Power/Standby status.



KLA12

Housed in a rugged ABS enclosure that results in both light weight and long-term durability, the KLA12 features a 12-inch low-frequency transducer coupled with a 1.75-inch compression driver. Designed to be used exclusively as a fixed arcuate line array, each KLA12 is set at a 90° x 18° splay angle, allowing 90° vertical arrays to be configured using only five boxes (most other solutions require six). KLA's unique self-contained SOLO™ (Single-Operator Logistics) Rigging System enables users to quickly assemble (and disassemble) the line array in a fraction of the time without the need for special tools or external hardware.



SOLO™ Rigging System

KLA12's Ar-Q™ (Arcuate Equalization) processing enables users to quickly tune the array, making appropriate frequency compensation adjustments based on the number of boxes. With the click of a dial, the user can select the total number of boxes deployed in the array resulting in an evenly balanced and accurate tonal curve. QSC's proprietary Intrinsic Correction™, first introduced with the WideLine™ Series, actively adjusts time, frequency and amplitude response to achieve a maximally flat bandpass target.

KLA181

In addition to DEEP™ DSP algorithm, GuardRail™, Auto Standby, balanced line-level XLR input with an XLR "Thru" connector, Attenuation Control and LED indicators, the KLA181 subwoofer also includes a polarity switch for low-frequency directivity control.



KLA181 shown with (2) KLA12

	KLA12	KLA181
Configuration	Multipurpose 2-way	18" vented subwoofer
Transducers		
High-Frequency	1.75" diaphragm compression driver	—
Low-Frequency	12" cone transducer	18" cone transducer
Frequency Response (-6 dB)	49 Hz – 18 kHz	38 Hz
Frequency Range (-10 dB)	44 Hz – 20 kHz	33 Hz
Nominal Coverage (-6 dB)	90 x 18 degree	—
Maximum SPL (1 meter)	128 dB	135 dB
Amplifiers		
Power Output	500 W x 500 W power module	1,000 W power module
Input Impedance (Ω)	XLR: 40k balanced / 20k unbalanced	XLR: 40k balanced / 20k unbalanced
Controls	Power • Attenuation • LF Setting (External Sub/Normal/DEEP™) • Array Size (1–5) • Front LED (Pwr/Limit/Off)	Power • Attenuation • LF Mode (Normal/DEEP™) • Polarity (Normal/ Reverse) • Front LED (Pwr/Limit/Off)
Indicators	Limit • Standby • Power • Signal	
Connectors	Balanced female XLR line level input • Balanced male XLR full range line level out • Remote attenuation control • Locking powerCON® power connector AC In • Locking powerCON® power connector AC Out	
Cooling	On demand, 50 mm variable speed fan	
Amplifier Protection	Thermal limiting • Output overcurrent • Overtemperature muting • GuardRail™	
Transducer Protection	Thermal limiting • Excursion limiting	
AC Power Input	Universal power supply 100 - 240 VAC, 50 - 60 Hz	
AC Power Consumption 1/8 Power	100 VAC, 8.0 A • 120 VAC, 7.2 A • 230 VAC, 4.2 A	
Enclosure	Impact resistant ABS	Painted birch plywood
Weight	54 lbs / 25 kg	100 lbs / 45.3 kg
Finish	Black or White Paint	Black or White textured paint
Grille	Black or White powder coated 18 gauge steel	
Dimensions (HWD)	15.0" x 23.4" x 16.6" (382mm x 594mm x 422mm)	21.6" x 23.1" x 25.7" (547mm x 586mm x 653mm)
Available Accessories	KLA12 TOTE • K Series M10 KIT • KLA AF12 Array Frame	KW181 Pole

Rigging & Deployment

For maximum deployment flexibility, KLA loudspeakers can be either ground deployed or flown. As a ground stack, up to two KLA12 enclosures can be mounted over the KLA181 or the KW181 subwoofer via a threaded pole socket, or without a sub using an appropriately rated loudspeaker stand. KLA12 enclosures also feature the Tilt-Direct™ 35mm pole socket allowing the loudspeaker to be aimed downward 9° for the best audience coverage.

Up to five KLA enclosures (any combination of KLA12 and KLA181) can be flown via M10 fittings on the top of each enclosure. An optional KLA AF12 array frame is also available.



Example shown
with optional KLA
AF12 array frame

KLA Series

KLA12

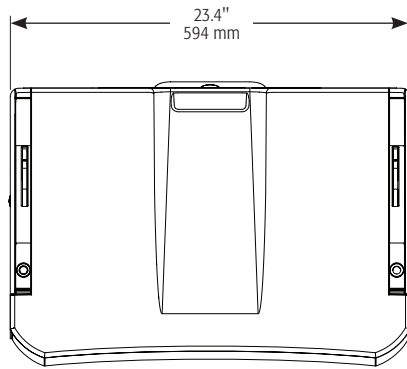

Top

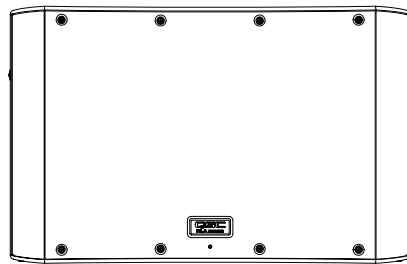
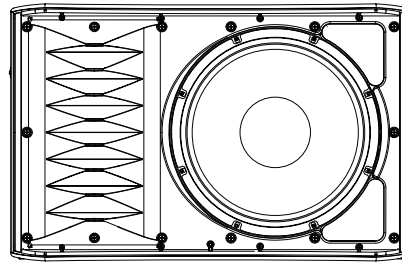

Front

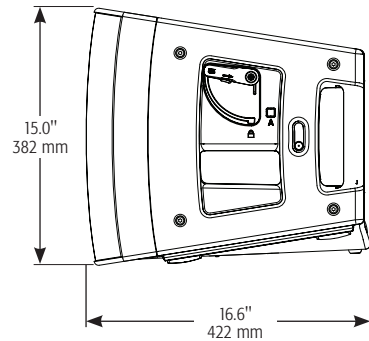

Side

KLA181

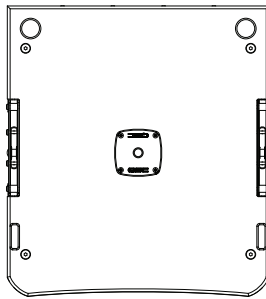

Top

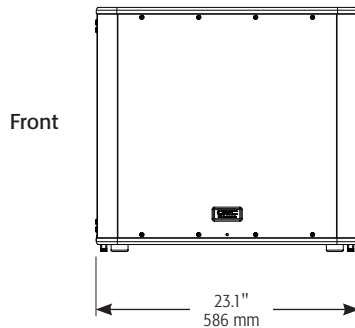
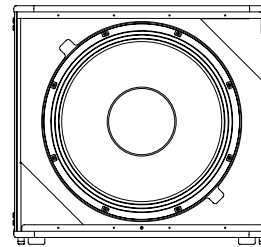

Front

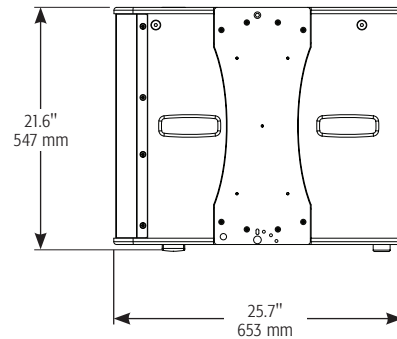

Side

Specifications subject to change without notice.